

User's Manual

Wireless Cube Fish-Eye IP Camera

▶ ICA-W8100



Copyright

Copyright © 2013 by PLANET Technology Corp. All rights reserved. No part of this publication may be reproduced, transmitted, transcribed, stored in a retrieval system, or translated into any language or computer language, in any form or by any means, electronic, mechanical, magnetic, optical, chemical, manual or otherwise, without the prior written permission of PLANET.

PLANET makes no representations or warranties, either expressed or implied, with respect to the contents hereof and specifically disclaims any warranties, merchantability or fitness for any particular purpose. Any software described in this manual is sold or licensed "as is". Should the programs prove defective following their purchase, the buyer (and not PLANET, its distributor, or its dealer) assumes the entire cost of all necessary servicing, repair, and any incidental or consequential damages resulting from any defect in the software. Further, PLANET reserves the right to revise this publication and to make changes from time to time in the contents hereof without obligation to notify any person of such revision or changes.

All brand and product names mentioned in this manual are trademarks and/or registered trademarks of their respective holders.

Federal Communication Commission Interference Statement

This equipment has been tested and found to comply with the limits for a Class B digital device, pursuant to Part 15 of FCC Rules. These limits are designed to provide reasonable protection against harmful interference in a residential installation. This equipment generates, uses, and can radiate radio frequency energy and, if not installed and used in accordance with the instructions, may cause harmful interference to radio communications. However, there is no guarantee that interference will not occur in a particular installation. If this equipment does cause harmful interference to radio or television reception, which can be determined by turning the equipment off and on, the user is encouraged to try to correct the interference by one or more of the following measures:

1. Reorient or relocate the receiving antenna.
2. Increase the separation between the equipment and receiver.
3. Connect the equipment into an outlet on a circuit different from that to which the receiver is connected.
4. Consult the dealer or an experienced radio technician for help.

FCC Caution

To assure continued compliance, for example, use only shielded interface cables when connecting to computer or peripheral devices. Any changes or modifications not expressly approved by the party responsible for compliance could void the user's authority to operate the equipment.

This device complies with Part 15 of the FCC Rules. Operation is subject to the following two conditions: (1) This device may not cause harmful interference, and (2) this device must accept any interference received, including interference that may cause undesired operation.

Federal Communication Commission (FCC) Radiation Exposure Statement

This equipment complies with FCC radiation exposure set forth for an uncontrolled environment. In order to avoid the possibility of exceeding the FCC radio frequency exposure limits, human proximity to the antenna shall not be less than 20 cm (8 inches) during normal operation.

Safety

This equipment is designed with the utmost care for the safety of those who install and use it. However, special attention must be paid to the dangers of electric shock and static electricity when working with electrical equipment. All guidelines of this and of the computer manufacture must therefore be allowed at all times to ensure the safe use of the equipment.

CE Mark Warning

This is a Class B product. In a domestic environment, this product may cause radio interference, in which case the user may be required to take adequate measures.

WEEE Regulation



To avoid the potential effects on the environment and human health as a result of the presence of hazardous substances in electrical and electronic equipment, end users of electrical and electronic equipment should understand the meaning of the crossed-out wheeled bin symbol. Do not dispose of WEEE as unsorted municipal waste; they should be collected separately.

Revision

User's Manual for PLANET Wireless Cube Fish-Eye IP Camera
Model: ICA-W8100
Rev: 1.00 (February.2013)
Part No. EM-ICAW8100

Table of Contents

Chapter 1.	Product Introduction.....	6
1.1	Package Contents	6
1.2	Overview	6
1.3	Features	8
1.4	Product Specifications.....	9
Chapter 2.	Hardware Interface.....	11
2.1	Physical Descriptions	11
2.2	Hardware Installation	14
2.3	Initial Utility Installation	16
2.4	Preparation	18
2.4.1	Configuring Network by PLANET IPInstaller.....	18
2.4.2	Opening the Web-based UI of Select Camera	19
2.5	Using UPnP of Windows XP or 7	20
2.5.1	Windows XP	20
2.5.2	Windows 7	24
2.6	Setup ActiveX to use the Internet Camera	25
2.6.1	Internet Explorer 6 for Windows XP	26
2.6.2	Internet Explorer 7 for Windows XP	26
2.6.3	Internet Explorer 7 for Windows Vista.....	27
Chapter 3.	Cloud Installation.....	29
3.1	CloudLync Account Registration by PC & Notebook.....	29
3.1.1	Registration through CloudLync “Create Account”	29
3.1.2	Registration through Google Account	30
3.2	Binding Camera into CloudLync by PC & Notebook	31
3.2.1	Binding Camera for the First Time.....	31
3.2.2	Modifying Camera Default Names.....	34
3.3	CloudLync Account Registration by Smartphone & Tablet	35
3.3.1	Downloading CloudLync App.....	35
3.3.2	CloudLync Registration through “Create Account”	35
3.3.3	CloudLync Registration through “Google Account”	36
3.4	Binding Camera into CloudLync by Smartphone & Tablet.....	38
Chapter 4.	Web-based Management.....	40
4.1	Introduction	40
4.2	Connecting to Internet Camera	40
4.3	Live View	41
4.4	System Configuration.....	43
4.4.1	Information Tab	43
4.4.2	Time Tab	44
4.4.3	Security Tab.....	45
4.4.4	Maintenance Tab	46
4.5	Network Setup Execution	47
4.5.1	General Tab	47
4.5.2	Wireless Tab.....	49
4.5.3	DDNS Tab.....	50
4.6	Video & Audio Setup Execution	51
4.6.1	Stream Tab	51
4.6.2	Video Tab.....	54
4.6.3	Audio Tab	55

4.6.4 Privacy Mask Tab	55
4.7 Event Setup Execution	57
4.7.1 Motion Tab	57
4.7.2 Video Tab	59
4.7.3 Snapshot Tab	61
4.8 Local Storage Setup Execution	65
4.8.1 Local Storage Tab	65
4.8.2 Playback Tab	66
4.9 CloudLync Setup Execution (For ICA-W8100-CLD)	66
Appendix A: PING IP Address	67
Appendix B: DDNS Application	68
Appendix C: Configure Port Forwarding Manually	69
Appendix D: Troubleshooting & Frequently Asked Questions	69
Appendix E: EC Declaration of Conformity	73

Chapter 1. Product Introduction

1.1 Package Contents

The package should contain the following items:

- Camera unit x 1
- Power Adapter x 1
- User's Manual CD x 1
- Quick Installation Guide x 1
- Stand Package x 1
- Bracket x 1
- Cloud Activation Card x 1 (For ICA-W8100-CLD model only)

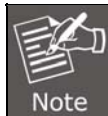

1. If any of the above items are missing, please contact your dealer immediately.
2. Using the power supply that is not the one included in the Internet Camera packet will cause damage and void the warranty for this product.

1.2 Overview

Compact Wireless Panoramic Camera for Wide View Surveillance

PLANET ICA-W8100 is a compact cube camera providing a 180 degree panoramic wide angle view, especially designed for indoor surveillance. Incorporating 1.3MP-resolution sensors, it supports H.264, MPEG-4, and M-JPEG compression formats and delivers excellent picture quality in up to 1280 x 720 pixels (720P) at 30 frames per second (fps). The unique design makes it the ideal solution to surveillance applications in boutiques, stores or restaurants.



Wider Monitoring with 180° Panoramic View

The ICA-W8100 wireless fisheye camera allows you to monitor all angles of a location using just one camera, thus saving lots of traditional mechanical Pan/Tilt maintenance effort. The distorted hemispherical image of the fisheye camera will be converted into the conventional rectilinear projection. Without the need of installing any other software and with the ICA-W8100, you can watch live view and utilize functions such as motion detection through the Web interface via an IE browser.



Efficient Event Management

The ICA-W8100 is designed with a built-in **Passive InfraRed (PIR)** motion detection sensor able to detect movement far from 5 meters away. When people pass by or an emergency happens in the specified areas, the ICA-W8100 will “detect” and start recording automatically. Furthermore, it provides an additional function of alarm notification that can send the captured images to the micro SD/SDHC card slot for local storage.



Enhanced Video Quality and 2-way Audio Support

The ICA-W8100 provides the industry a more comprehensive set of performance enhancing features including Auto Electronic Shutter (AES) and Auto White Balance (AWB). Besides, the ICA-W8100 supports 2-way audio to strengthen the event management capabilities.

Two-Way Audio



High Quality Streaming via 11n Wireless Connectivity

The ICA-W8100 adopts IEEE 802.11n wireless technology to communicate at maximum wireless signal rate and ensures secure transmission with WEP and WPA encryptions. It allows you to stream high quality video to remote sites and mobile devices. A Site Survey feature also allows you to view and connect to nearby wireless networks with ease. Complying with ONVIF, the ICA-W8100 is therefore interoperable with the third brand camera in the market, which greatly supports users to integrate with their existing surveillance network. It also includes 64-CH central management software for ease of maintenance and remote monitoring. The ICA-W8100 is indisputably the top choice for reliable and high performance surveillance.

1.3 Features

- **Camera**
 - Fish-Eye Lens to bring 180° panoramic wide angle view
 - Unique Fish-Eye hardware correction technology
 - 1.3 mega-pixel CMOS sensor
 - Passive Infrared (PIR) Sensor for enhanced motion detection
- **Video / Audio**
 - H.264, MPEG-4 and M-JPEG video compression simultaneously
 - Simultaneous multi-H.264 streams support
 - 2-way audio support with enhanced audio quality
- **Network and Configuration**
 - Wireless 802.11n connectivity / Wi-Fi Protected Setup (WPS)
 - UPnP® support for network setup & configuration
 - Auto MDI/MDI-X supported
 - RTSP / UPnP / 3GPP / HTTPS protocols selectable
- **Easy Installation & Management**
 - ONVIF compliant for interoperability
 - Advanced e-PTZ, including preset point
 - Plug and Play Smart Access Technology without IP setting in router
 - Micro SD/SDHC card local video recording supported
 - Cam Viewer 3 central management software supported

1.4 Product Specifications

Product	ICA-W8100 Wireless Cube Fisheye IP Camera
Camera	
Image Device	1/4" progressive 1.3 mega-pixel scan CMOS sensor
Lens	Fish-Eye Lens, 185.5/145/>=200° (H/V/D), F= 2.0, f=0.89 mm
Min. Illumination	0.5 lux @ F2
Effective Pixels	1280 x 720 pixels (16:9)
PIR Sensor	1 x Built-in sensor with adjustable 70 degrees direction Effective Distance: 5 meters Effective Coverage: 70 degrees
Video	
Video Encoder	H.264 / MPEG-4 / M-JPEG
Video Resolution	H.264: 1280 x 720 / 640 x 360 / 320 x 180 MPEG4: 1280 x 720 / 640 x 360 / 320 x 180 M-JPEG: 1280 x 720 / 640 x 360 / 320 x 180
Frame Rate	Up to 30fps for all resolutions
Image Setting	AE, AWB, Brightness, Saturation, Contrast, Mirror/Rotate, Color/BW
Streaming	Simultaneously multi-profile streaming Streaming over UDP, TCP, or HTTP M-JPEG streaming over HTTP (server push) Controllable frame rate and bandwidth Constant and variable bit rate (M-JPEG / H.264)
Rate Control	CBR (Constant Bit Rate) VBR (Variable Bit Rate)
UI Layout	180° Single Broad View (1P) 2 PTZ Mode (2R) 180° Broad View + 2 PTZ Mode (1P2R)
Audio	
Audio Streaming	2-way Audio
Audio Compression	RTSP: G.711 64kbps
Microphone	Built-in Microphone
Audio Output	Line Out for extra speaker
Network and Configuration	
Network Standard	IEEE 802.3 10Base-T IEEE 802.3u 100Base-TX IEEE 802.11b/g/n
Network Protocol	IPv4, TCP/IP, UDP, HTTP, HTTPS, SMTP, FTP, NTP, DNS, DDNS, DHCP, ARP, Bonjour, UPnP, RTSP, RTP, RTCP, IGMP, PPPoE, 3GPP, ICMP, Samba
Antenna connector	1 x 3dBi (max)
Frequency	2.4GHz
RF Transmission Power	OFDM: 13dBm CCK: 17dBm
Output Power	802.11n: 13dBm(default) +/- 1dBm 802.11g: 13dBm(default) +/- 1dBm

	802.11b: 17dBm(default) +/- 1dBm
Data Rate	802.11b: 1, 2, 5.5, 11Mbps 802.11g: 6, 9, 12, 18, 24, 36, 48, 54Mbps 802.11n: up to 150Mbps
Security	Password protection / WEP and WPA Encryption
Users	Depends on streaming data rate used
System Integration	
Application Programming Interface	Open API for software integration ONVIF
Alarm Triggers	Intelligent video motion detection and PIR sensor
Alarm Events	File upload via FTP, e-mail or Micro SD/SDHC card Notification via e-mail, Mobile APP, and HTTP
Environment	
Power Requirements	5V DC, 2A
Power Consumption	6W (5VDC)
Operating Temperature	0 ~ 45 degrees C
Operating Humidity	20 ~ 80% (non-condensing)
Weight	134g
Dimensions (W x D x H)	70 x 39 x 99 mm
Emission	CE, FCC
Connectors	10/100 Mbps Ethernet, RJ-45 DC power jack Audio out Micro SD/SDHC card (max. 32GB, Class 6) WPS Button Factory default reset button

Chapter 2. Hardware Interface

2.1 Physical Descriptions

Dimensions	70 x 39 x 99 mm
Weight	134g (gross weight)

➤ Front Panel

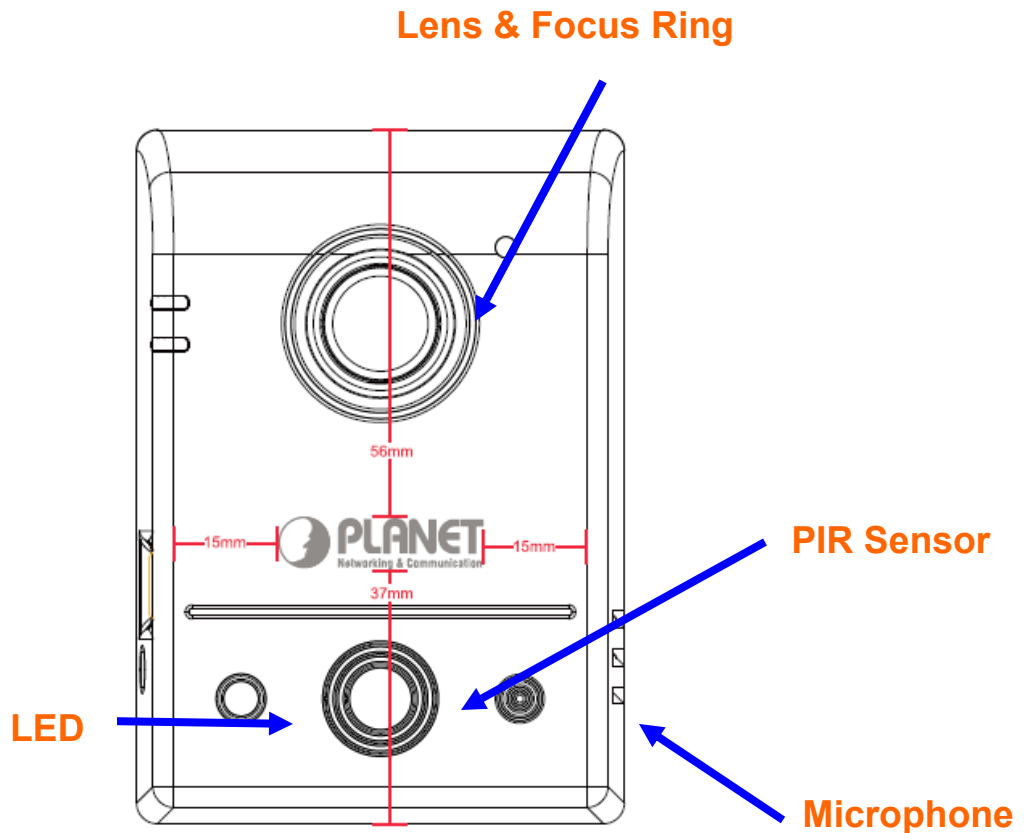

Interface	Description
Lens & Focus Ring	User can use this ring to adjust focus manually.
MIC	The camera has a built-in microphone. This microphone is hidden in the pinhole located on the front panel.
PIR Sensor	PIR sensor is used to sense motion or detect whether a human has moved in or out of the sensors range.
LED	When camera detects a moving individual, the LED will light up.

➤ **Bottom Panel**

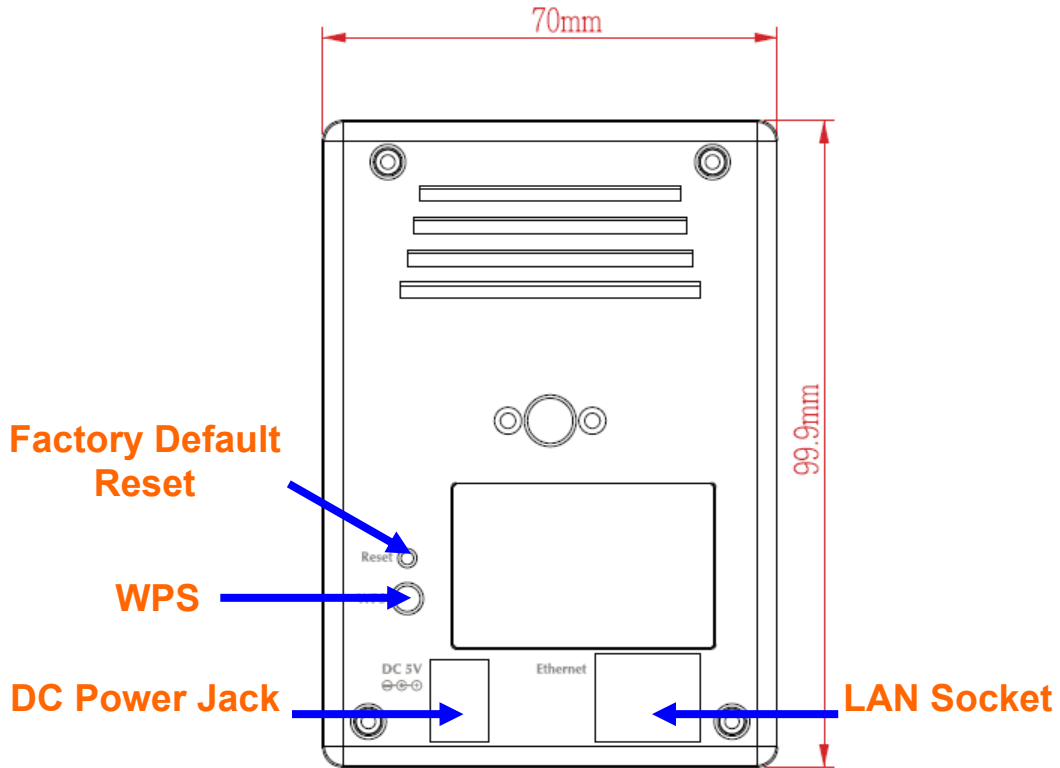

➤ **Side Panel**

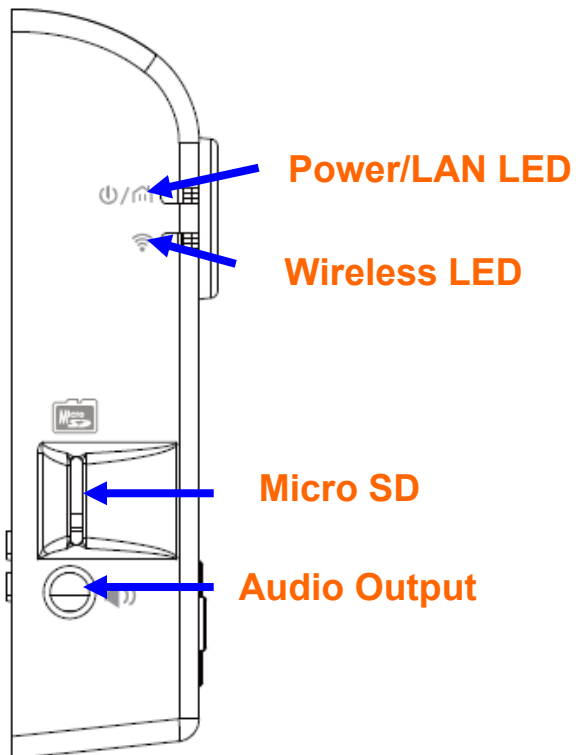

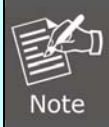
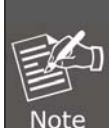
Interface	Description
Audio Output Jack	Audio-out jack allows this device to output audio signal.
DC Power Jack	<p>The input power is 5VDC.</p> <div style="border: 1px solid black; padding: 5px; margin-top: 10px;">  <p>Note It supplies the power to the camera with the power adapter included in package. Otherwise, the improper power adapter may damage the unit and result in danger.</p> </div>
Factory Default Reset	<p>This button is hidden in the pinhole. This button is used to restore the all factory default settings. Sometimes restarting the camera will make the system back to a normal state. If the system still gets problems after restart, user can restore the factory default settings and install it again. To restore the device, please follow the steps below:</p> <ol style="list-style-type: none"> 1. Unplug the power jack to turn off the power of the camera. 2. Insert a pin into the reset hole as circled with red in the figures below. Sense a button and keep it pressed until instructed to release. 3. Plug in the power jack to turn on device. In about few seconds, the status LED will quickly flash. 4. Release the button (remove the pin from the reset hole). The camera should now be back to factory default. <div style="border: 1px solid black; padding: 5px; margin-top: 10px;">  <p>Note Restoring the factory default setting will lose all the previous settings including IP address forever. User needs to run the IPInstaller program to search the device and configure it to let the device work properly again.</p> </div>
LAN Socket	The LAN socket is a RJ-45 connector for connection to 10Base-T Ethernet or 100Base-TX Fast Ethernet cabling. This Ethernet port built-in N-Way protocol can detect or negotiate the transmission speed of the network automatically. Please use Category 5 cable to connect the Network Camera to a 100Mbps Fast Ethernet network switch or hub.
Power/LAN LED (green color)	When the LED turns green, it means camera has linked to Internet.
Wireless LED (orange color)	When the lower LED turns blue. It means wireless network has connected successfully
Micro-SD	User can insert a micro SD card into this slot for event recording.
WPS	Press the WPS button and hold it for 3 seconds to enable the WPS function. The LED will flash very fast, meaning it is connecting. When connecting with the router, the LED flashes will slow down, meaning connection is successful.

2.2 Hardware Installation

2.2.1 Wall, Ceiling and Table Mounting Installation

Step 1. Use the 2 supplied screws to fix the base plate to a flat surface.

Step 2. Loosen the lock ring to adjust the desired angle of the camera.

Step 3. Tighten the lock ring.

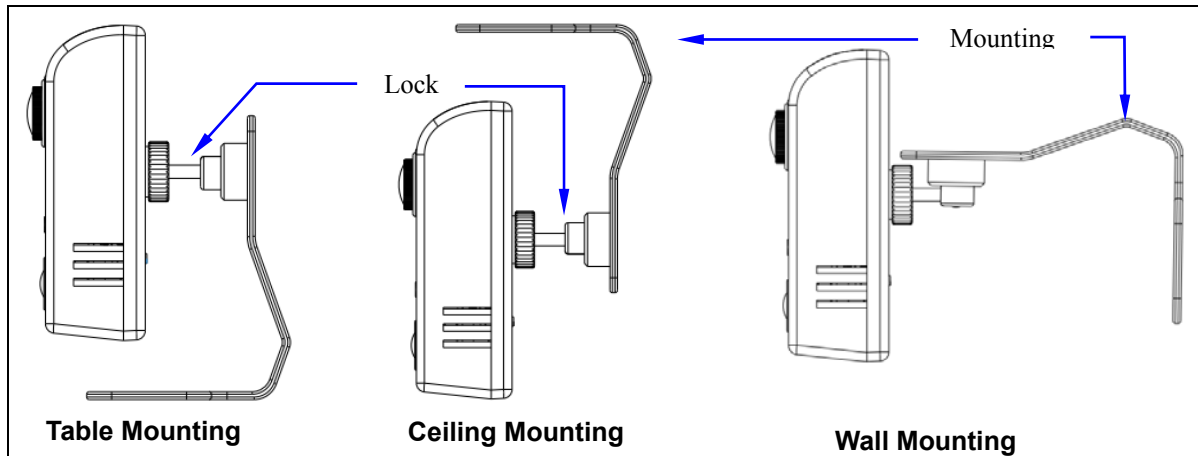

2.2.2 Network Installation

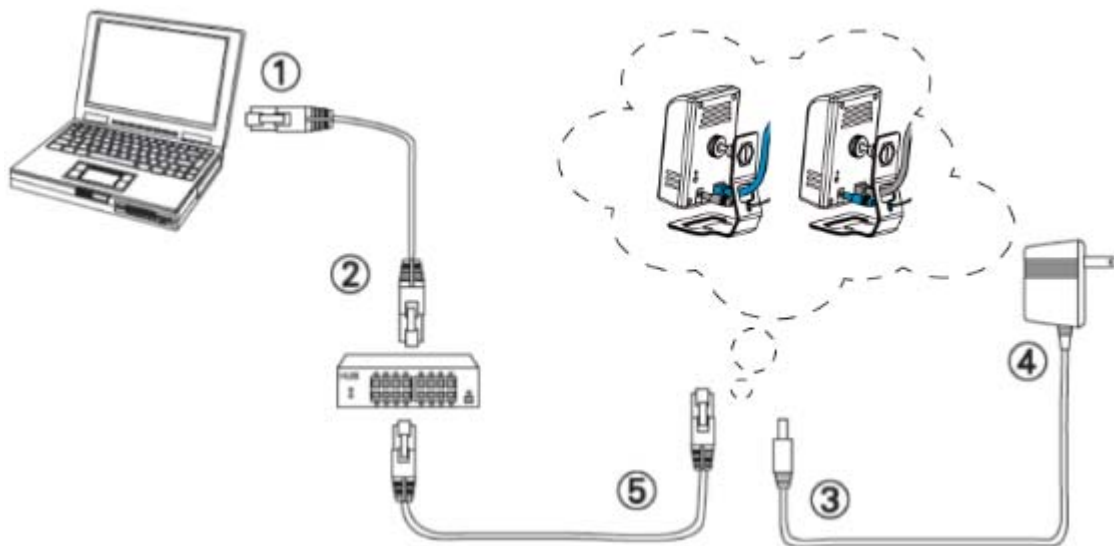

Step 1. Prepare a PC with Ethernet link to the network

Step 2. Plug an Ethernet cable into the LAN port (RJ-45) of the IP camera, and connect the camera to a network switch.

Step 3. Attach the power adapter to the IP camera, and connect the other end of the power adapter to a power outlet.

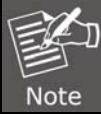

Only use the power adapter supplied with the IP camera; otherwise, the product may be damaged.

Step 4. Ensure the power adaptor specification matches the power system (110V or 220V) and connect the adaptor to the outlet.

Step 5. Connect the LAN port (RJ45) of the camera to a network router.

Step 6. You can skip Installation Guide Wizard and start CloudLync registration process. (In the following pages) If the upper LED did not turn green, we recommend you use the “Cloud Quick Installation Guide” to easily guide you to changing proper setting of your camera to make it connected to Internet. **(For ICA-W8100-CLD model only)**

Power/Network LED Indicator should light up in green to indicate successful link to the Internet

Wireless LED Indicator



If the upper LED does not turn green, refer to the “Installation Guide Wizard” application program in the CD which will further guide you in detail on how to properly set up your camera for Internet connection.

2.2.3 Through Wi-Fi Protected Setup (WPS)

To connect the camera in wireless mode, you need to have a Wi-Fi router with WPS button.

Step 1. With camera power connected and switched on, press and hold the WPS button (at the back of the camera) for 3 to 4 seconds and then release the button. The wireless LED Indicator (lower LED) will then start to flash and keep on flashing in blue once every second.

Step 2. Within one minute, press the Wi-Fi router WPS button to interface with the camera.



Step 3. When successful connection is established between the camera and Wi-Fi router, the lower LED Indicator will then stabilize and light up in blue while the upper LED remains lit in green.

Then proceed to start CloudLync registration and binding process as discussed in Chapter 3.

With wireless setup, the Power/Network LED Indicator should remain lit in green

When the camera is successfully connected to Wi-Fi, the Wireless LED Indicator stops flashing & lights up steadily in blue



If the LED does not turn steadily in blue, refer to the “Installation Guide Wizard” application program in the CD which will further guide you in details on how to properly set up your camera for Internet Wi-Fi connection.

2.3 Initial Utility Installation

This chapter shows how to quickly set up your H.264 camera. The camera is with the default settings. However to help you find the networked camera quickly the windows utility PLANET IPInstaller can search the cameras in the network that will help you to configure some basic setting before you start advanced management and monitoring.

Step 1. Insert the bundled CD into the CD-ROM drive to launch the auto-run program. Once completed, a welcome menu screen will appear.

Step 2. Click the “IPInstaller” hyperlink; you will see the dialog box as follows:

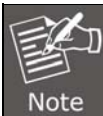

If the welcome screen does not appear, click “Start” at the taskbar. Then, select “Run” and type “D:\Utility\IPInstaller \ Planet IPinstaller.msi”, assume D is your CD-ROM drive.

Step 3. The “Welcome to the Install Shield Wizard for PLANET IPInstaller” prompt will display on the screen and click “Next” to continue.

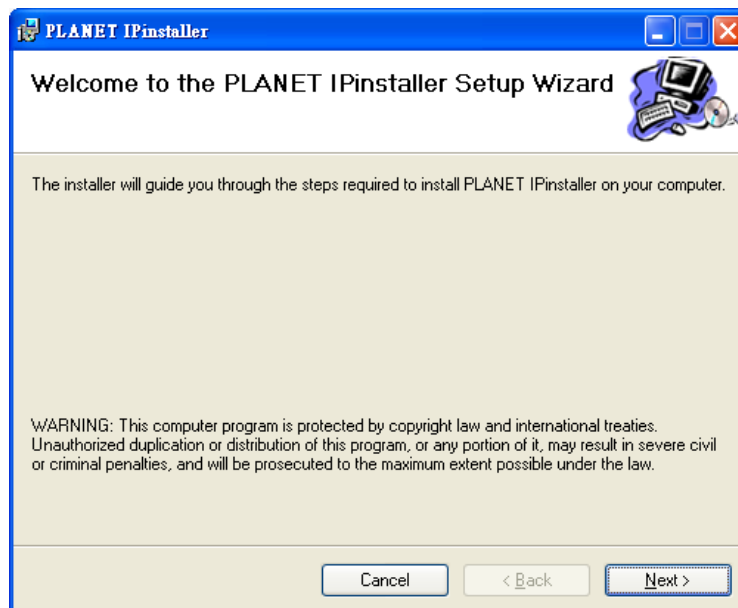

Step 4. Please click “**Next**” to install with original settings, or you may click “**Change...**” button to modify the install folder and then press “Next” to continue.

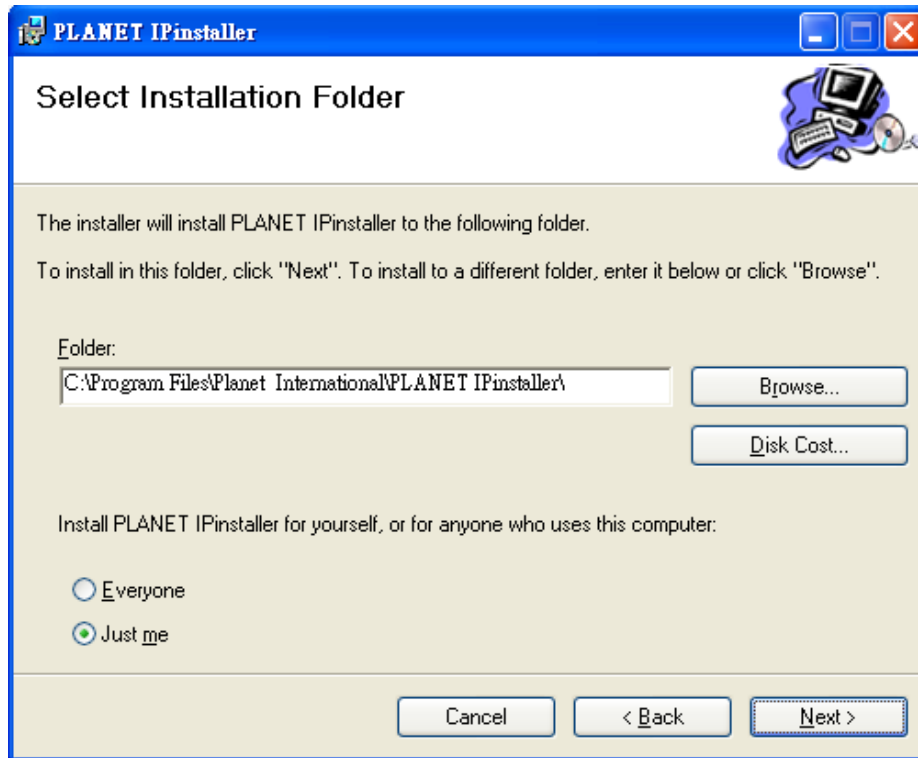

Step 5. Please click “**Next**” to start the installation.

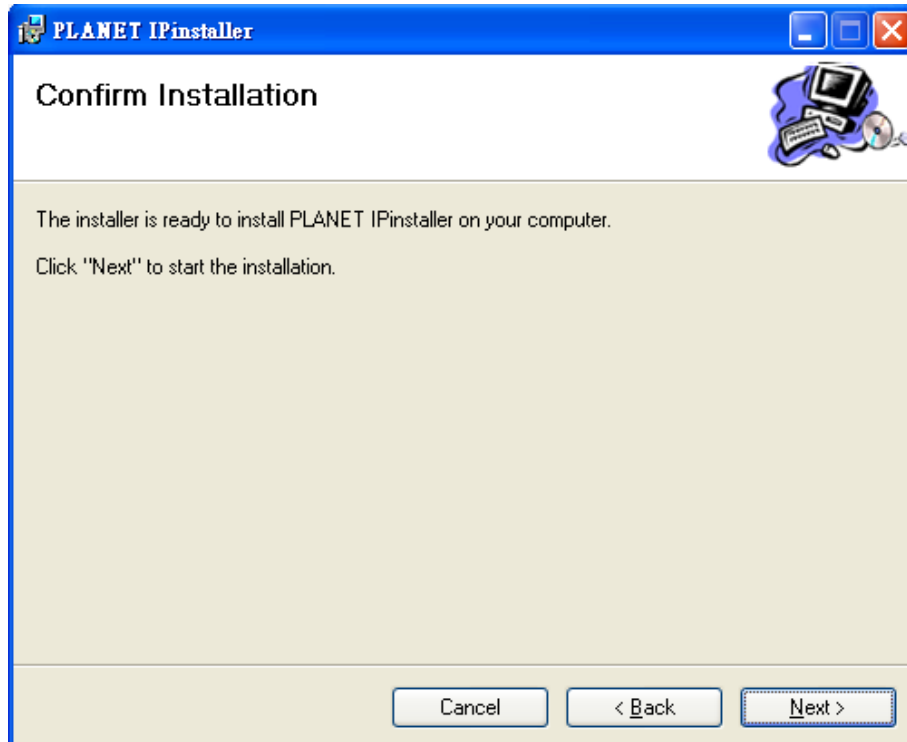

Step 6. Please click “Close” to complete the installation and launch program immediately.

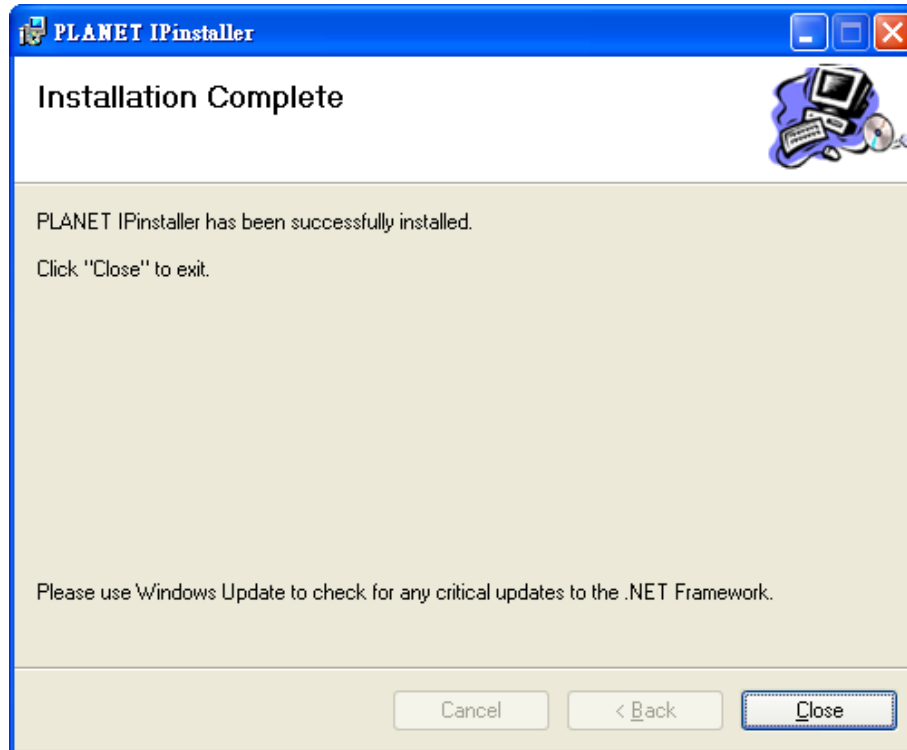

2.4 Preparation

When you install the camera in a LAN environment, you may execute PLANET IPInstaller to discover camera’s IP address and set up related parameters in the camera.

2.4.1 Configuring Network by PLANET IPInstaller

Please click “Device Search” button. PLANET IPInstaller will list all networked IP cameras in the LAN. If the IP camera is not found, you may check whether this IP camera is connected to the network properly and press the search button again.

Step 1. Click the menu bar **Tool > Device Search** to search the device in the LAN.

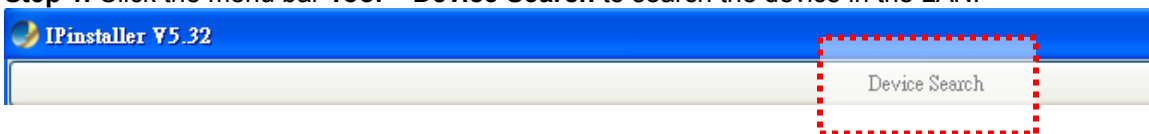

Step 2. Select an IP camera with the MAC address which corresponds to the IP camera to be configured.

Device Search					
	Model Name	IP Address	MAC Address	Firmware	SubnetMask
▶ 1	ICA-W8100	192.168.1.035	00-30-4f-a9-cf-f3	1.0.0_0712	255.255.255.0

Step 3. Double click the item to open the Property Page or click the **menu bar > Single Device Setting**.

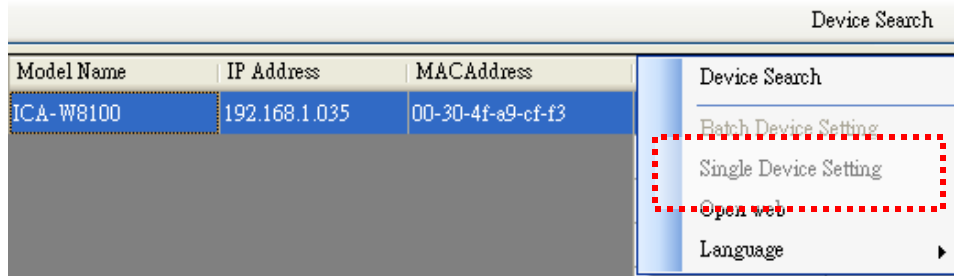

Step 4. After filling out the desired settings in the properties, click on “**Set**” button to complete the configuration settings.

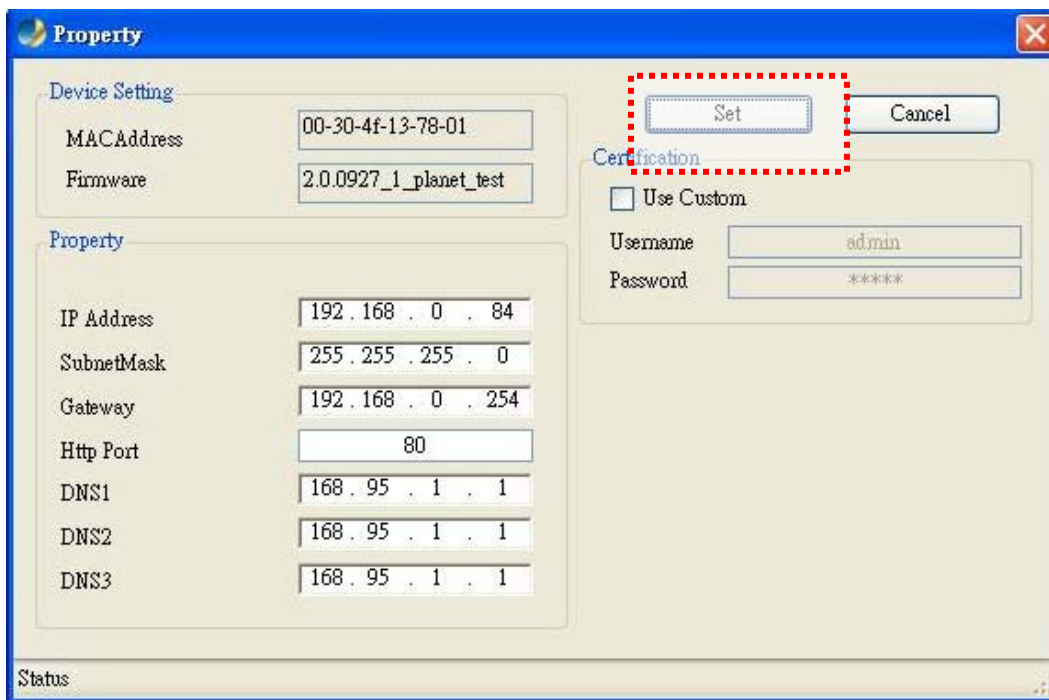

2.4.2 Opening the Web-based UI of Select Camera

If IPInstaller finds the IP camera, please select the device you want to view and click the “**Open Web**” button. Then you could see the video from the IP camera directly.

To access the Web-based UI of the selected unit, run the **menu bar > Open web** on the menu bar.

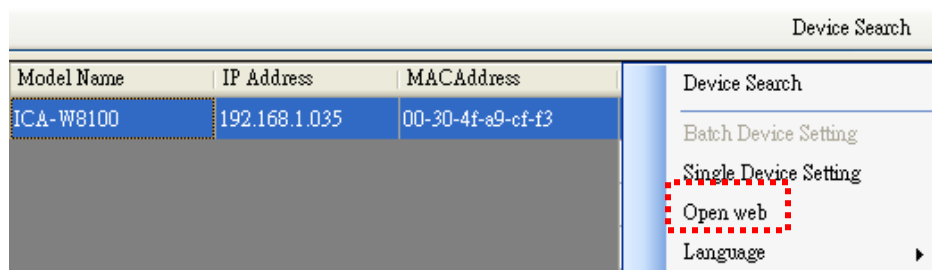

If the Internet camera is configured correctly, the default Web browser will open to the home page of the selected device.

If you find your browser is opened and automatically connected to the camera Home Page, it means you've assigned an IP Address to the unit successfully. Now you can close the IP Installer and start to use your camera.

2.5 Using UPnP of Windows XP or 7

2.5.1 Windows XP

UPnP™ is short for Universal Plug and Play, which is a networking architecture that provides compatibility among networking equipment, software, and peripherals. This device is an UPnP enabled device. If the operating system, Windows XP, of your PC is UPnP enabled, the device will be very easy to configure. Use the following steps to enable UPnP settings only if your operating system of PC is running Windows XP.

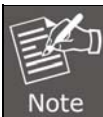

Please note that MS Windows 2000 does not support UPnP feature.

Go to **Start > Settings**, and Click **Control Panel**.

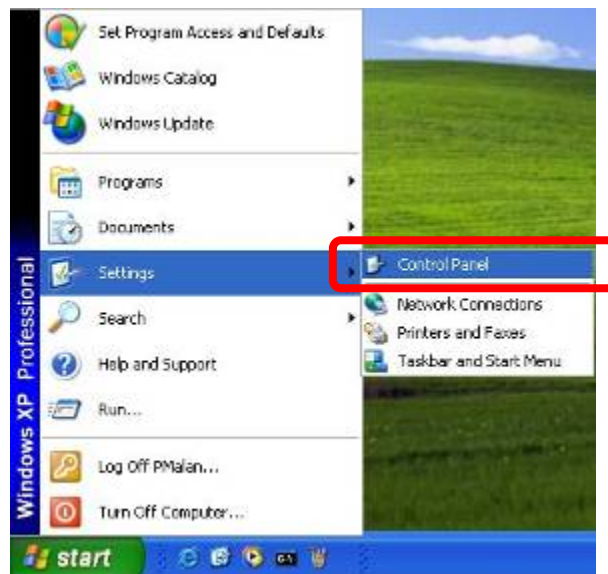

The “**Control Panel**” will display on the screen and double click “**Add or Remove Programs**” to continue.

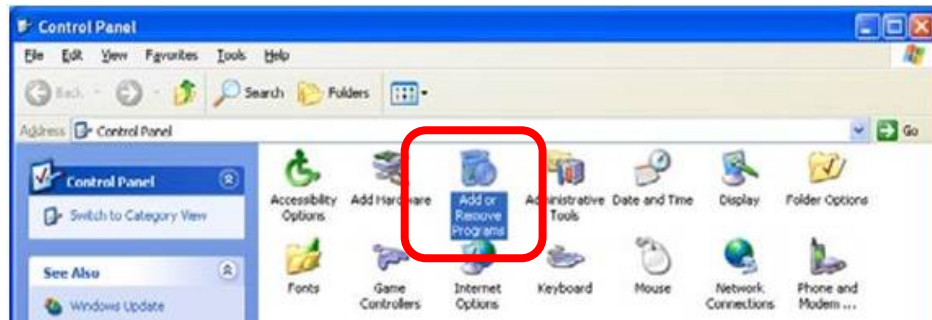

The “Add or Remove Programs” will display on the screen and click **Add/Remove Windows Components** to continue.

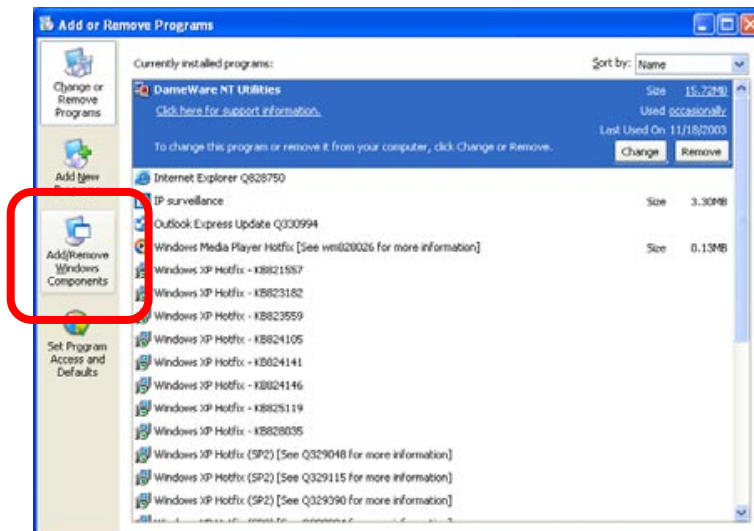

The following screen will appear, select “**Networking Services**” and click “**Details**” to continue.

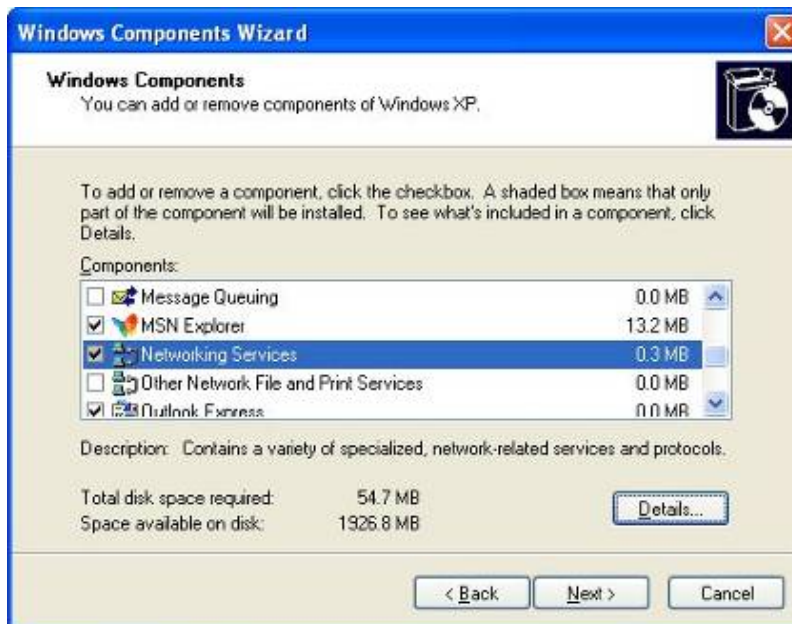

The “Networking Services” will display on the screen, select “**Universal Plug and Play**” and click “**OK**” to continue.

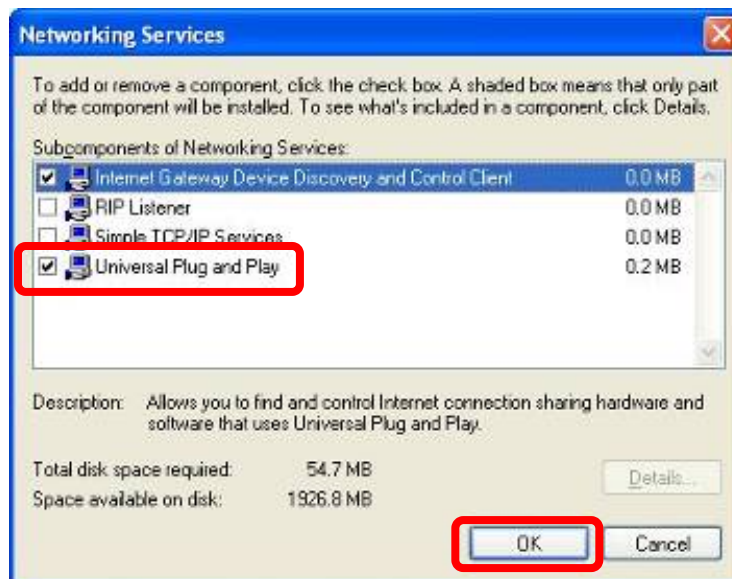

Please click “**Next**” to continue.

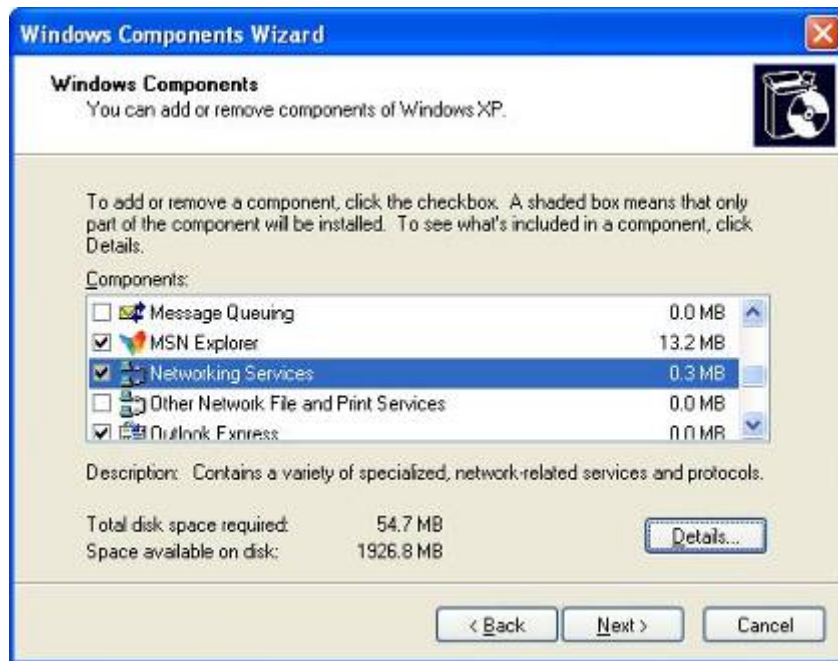

The program will start installing the UPnP automatically. You will see the below pop-up screen, please wait while Setup configures the components.

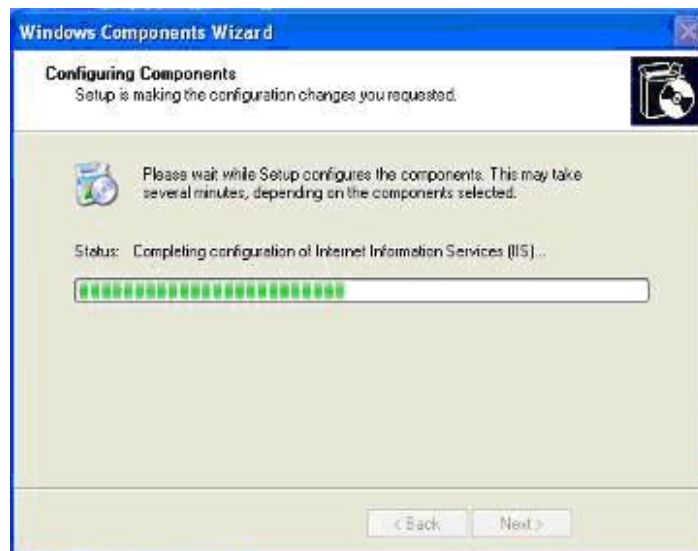

Please click **Finish** to complete the UPnP installation



Double-click **“My Network Places”** on the desktop, the “My Network Places” will display on the screen and double-click the UPnP icon with Internet camera to view your device in an internet browser.

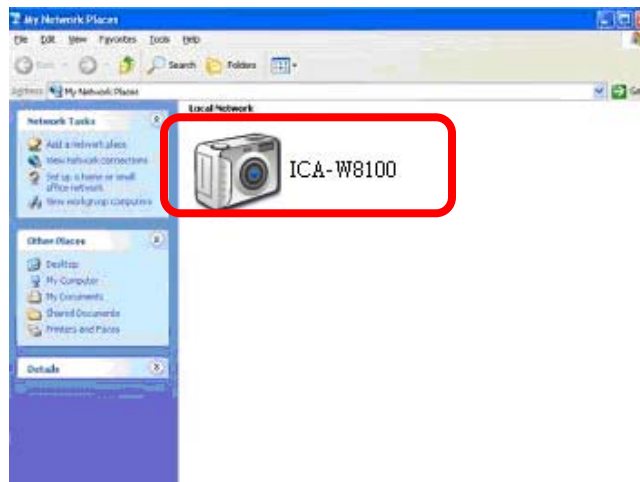

2.5.2 Windows 7

Go to **Start > Control Panel > Network and Internet > Network and Sharing Center**, if network discovery is off; click the arrow button  to expand the section.

Click Turn on network discovery, and then click Apply.  If you are prompted for an administrator password or confirmation, type the password or provide confirmation.

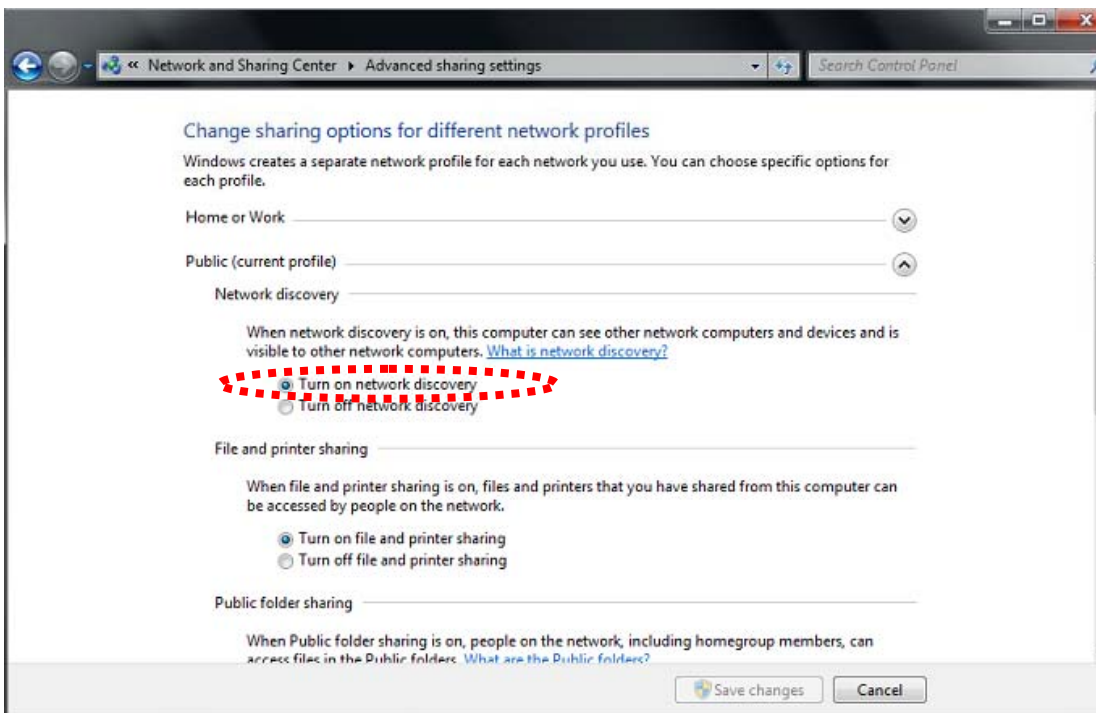
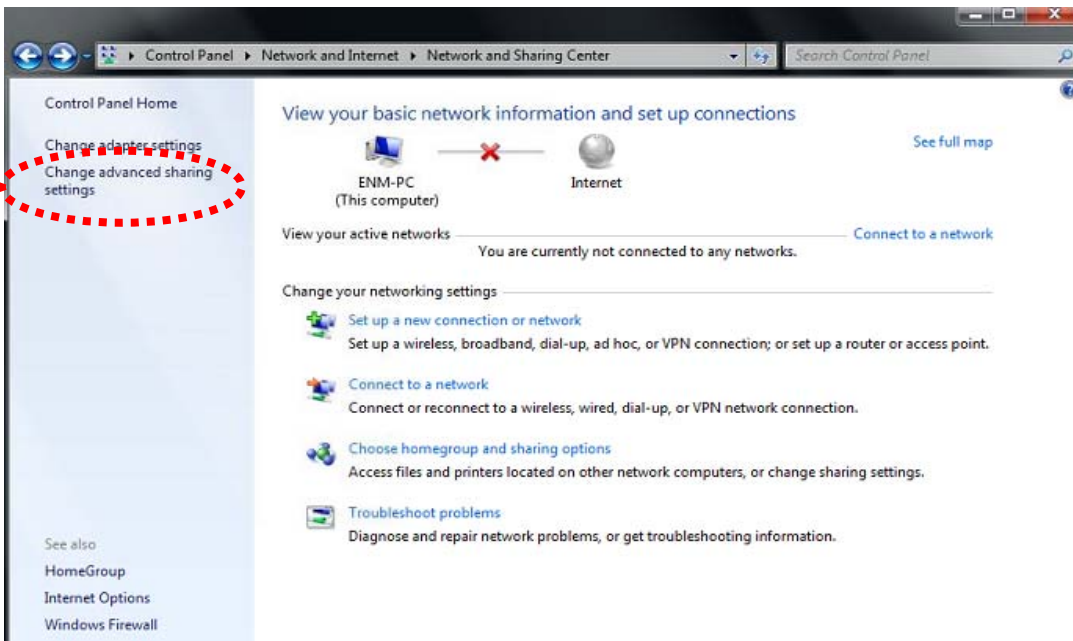

2.6 Setup ActiveX to use the Internet Camera

The Internet camera web pages communicate with the Internet camera using an ActiveX control. The ActiveX control must be downloaded from the Internet camera and installed on your PC. Your Internet Explorer security settings must allow for the web page to work correctly. To use the Internet camera, user must set up his IE browser as follows:

2.6.1 Internet Explorer 6 for Windows XP

From your IE browse → "Tools" → "Internet Options..." → "Security" → "Custom Level...", please set up your "Settings" as follows:

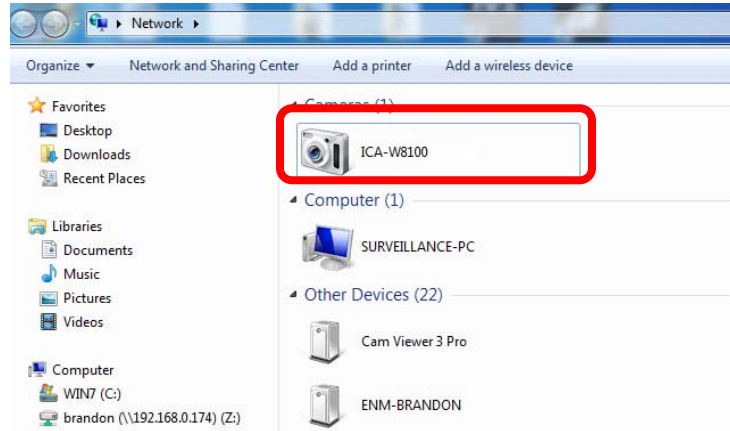

Set the first 3 items

- Download the signed ActiveX controls
- Download the unsigned ActiveX controls
- Initialize and script the ActiveX controls not masked as safe to Prompt

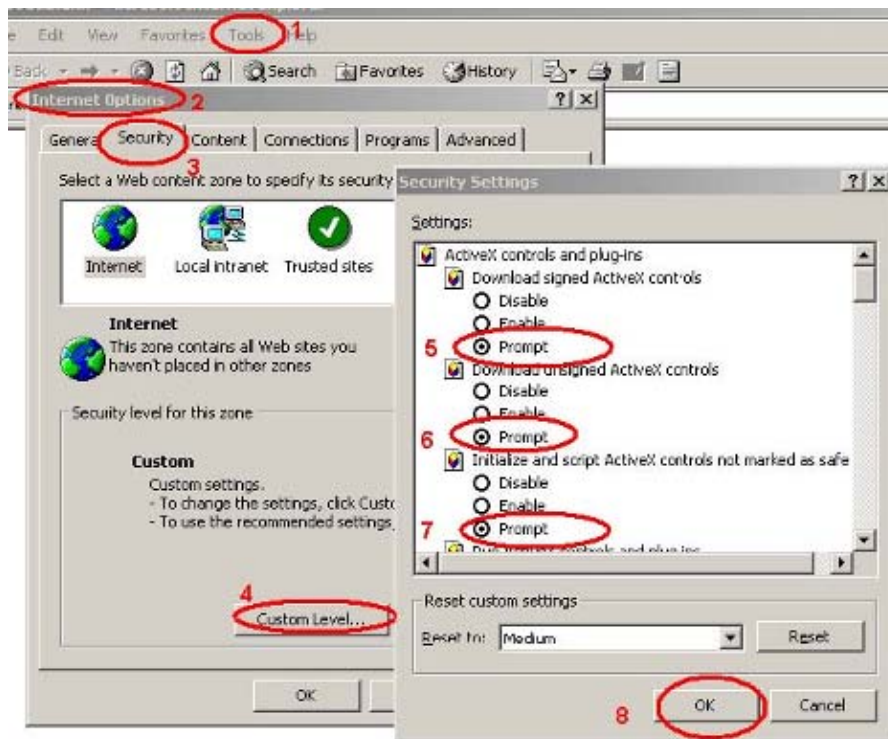

By now, you have finished your entire PC configuration for Internet camera.

2.6.2 Internet Explorer 7 for Windows XP

From your IE browse → "Tools" → "Internet Options..." → "Security" → "Custom Level...",

please set up your “Settings” as follows:

Set the first 3 items

- *Allow previously unused ActiveX control to run...*
- *Allows Scriptlets*
- *Automatic prompting for ActiveX controls*

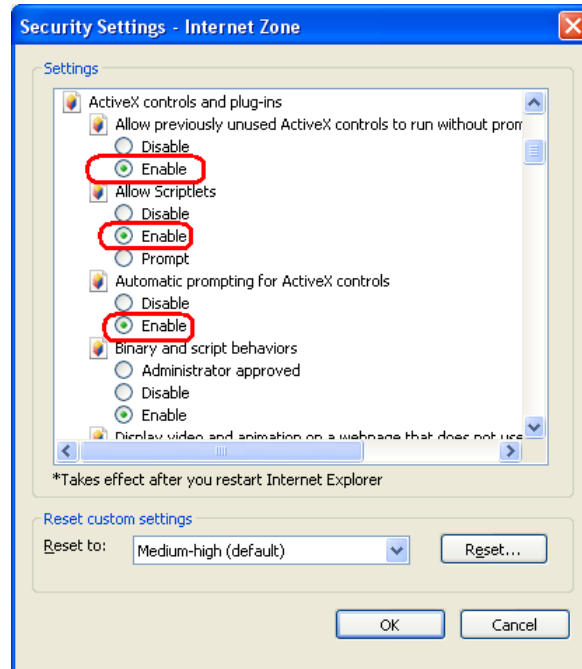

By now, you have finished your entire PC configuration for Internet Camera.

2.6.3 Internet Explorer 7 for Windows Vista

From your IE browse → ”Tools” → ”Internet Options...” → ”Security” → ”Internet” → ”Custom Level...”, please set up your “Settings” as follows:

- *Enable “Automatic prompting for ActiveX controls”*
- *Prompt “Initialize and script active controls not marked...”*

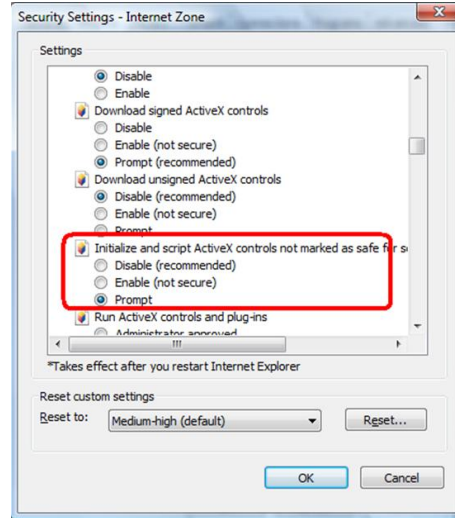
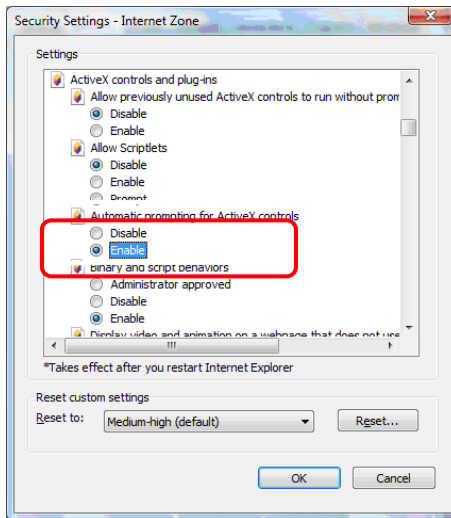

From your IE browser → "Tools" → "Internet Options..." → "Security" → "Trusted Sites" → "Custom Level...", please set up your "Settings" as follows:

- Enable "Automatic prompting for ActiveX controls"
- Prompt "Initialize and script active controls not marked..."

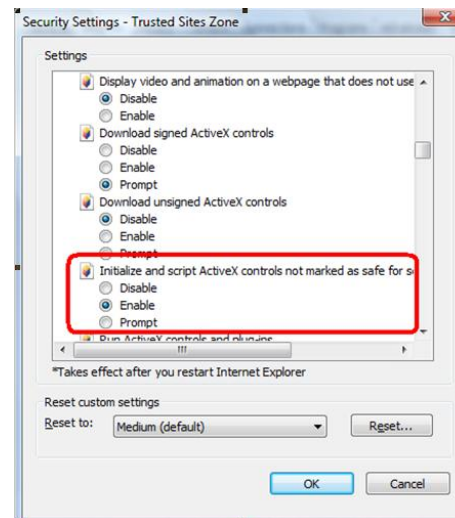
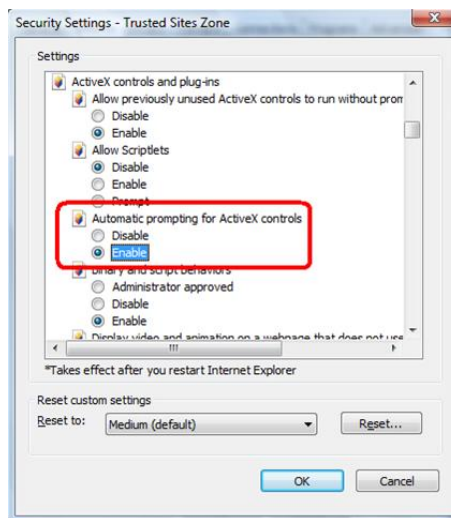

By now, you have finished your entire PC configuration for Internet camera.

Chapter 3. Cloud Installation

CloudLync is a Cloud NVR (Network Video Recorder) server that provides multiple Live View and Event Recording, and Playback of videos taken by your camera. It also allows you to make changes to your settings remotely. [\(For ICA-W8100-CLD model only\)](#)

3.1 CloudLync Account Registration by PC & Notebook

Visit CloudLync website <http://www.cloudlync.net/index.php>. When the following dialog displays, click **Create Account** button. If you already have an existing Google account, you may click **Google Login** button to use it as stand-in for your CloudLync account.

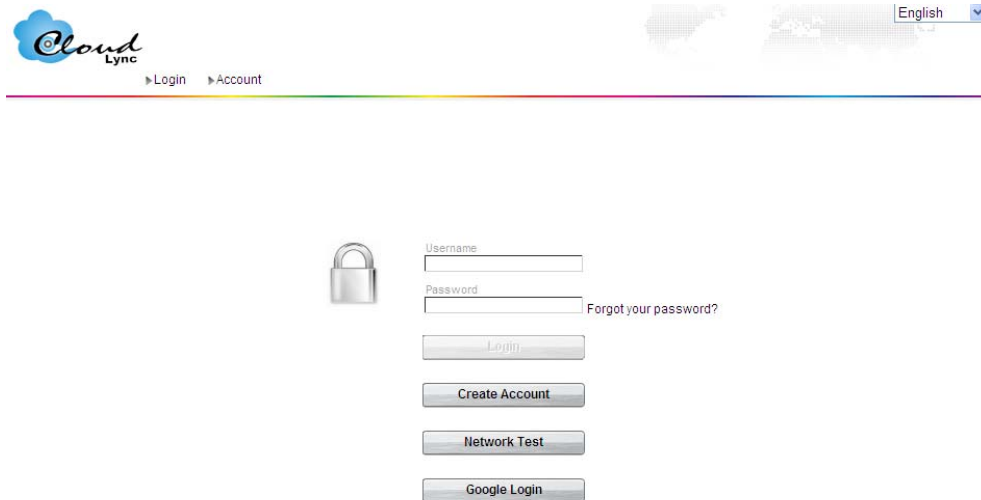

3.1.1 Registration through CloudLync “Create Account”

Step 1. After clicking **Create Account** button, the following dialog will then display to prompt you to define your own User Name, Password, and valid email address to start the account registration process.

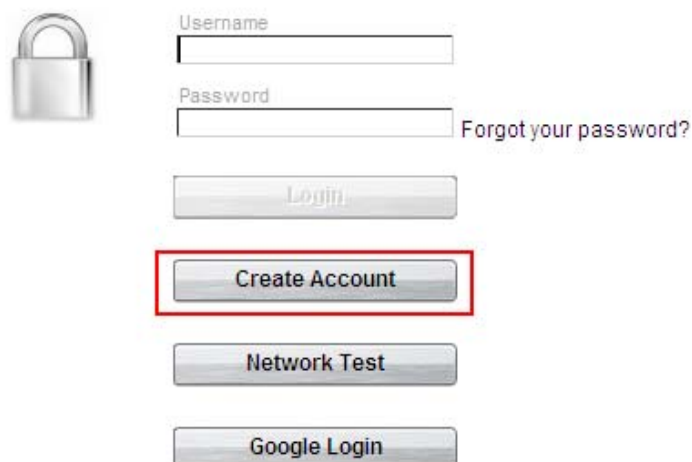

Step 2. After you have filled in all the necessary data, click Apply button (see figure above). A few minutes later, CloudLync will send you an Email message (shown below) to advise you of your newly created account number with instruction to verify your registration.

▶ Login ▶ Account

Apply Reset

Property	Content
Username	<input type="text"/>
Password	<input type="password"/>
Confirm Password	<input type="password"/>
Email	<input type="text"/>
Confirm Email	<input type="text"/>
Security Image	<input type="text"/> 8a7a8 Refresh Image

If you do not receive the email:
Try the following:

- Check your junk mail folder or spam filter.
- Try resending the email from [here](#).

*Please notice that the confirmation link will be valid only for 24 hours.

Step 3. Click the hypertext “Please click to verify your registration” and you will be automatically connected to CloudLync and prompt you with the process of binding the new camera into CloudLync.

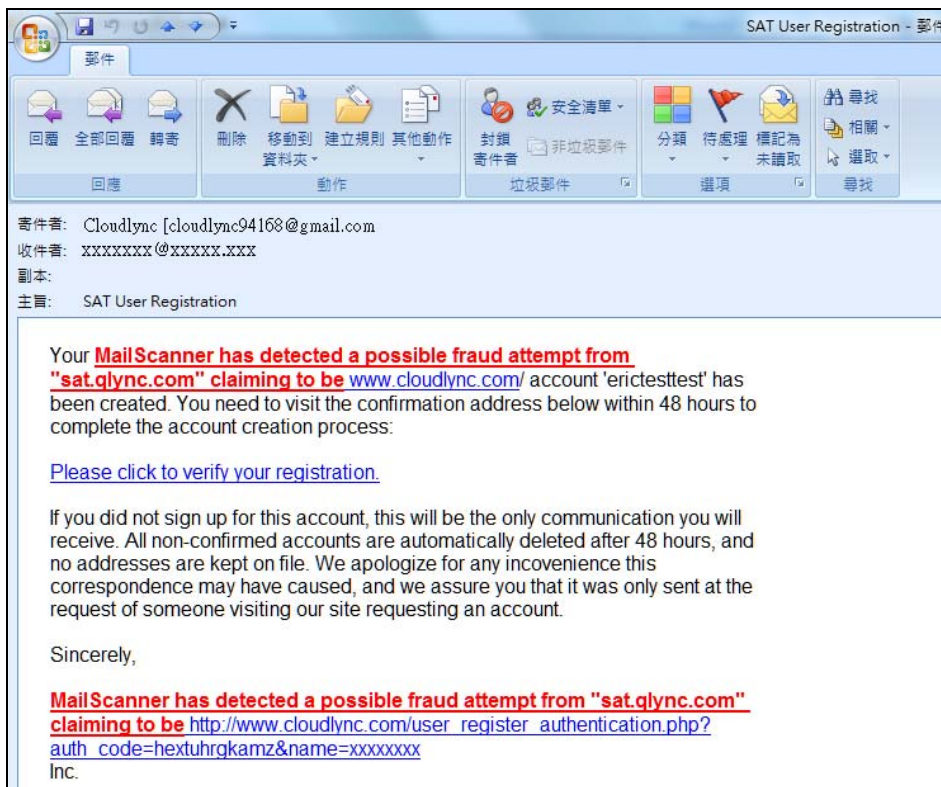

3.1.2 Registration through Google Account

CloudLync server allows you to use your Google account “User Name” and “Password” for your CloudLync account. This method is recommended and is easier and faster. Furthermore, CloudLync can use 5GB free space of your Google account to store backup video recorded in your Camera SD card.

Step 1. After clicking **Google Login** button, the following dialog will then display to prompt you to sign in your Gmail address and password.

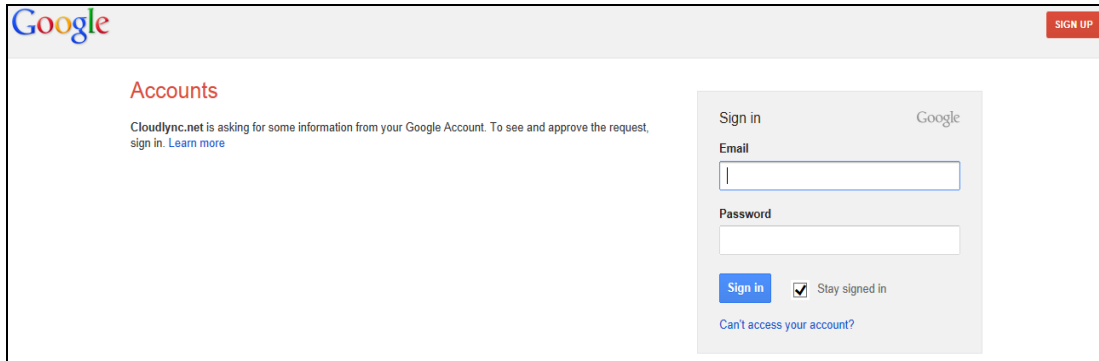

- Note**
1. Google Account provides 5GB free space for recorded video storage.
 2. With “Google Account” used to create the CloudLync account, you have to use your Gmail address as email address and click the “Google Login” button every time you need to log-in into CloudLync again.

Step 2. Click the **Sign in** button and you will be prompt with the process of binding the new camera into CloudLync

3.2 Binding Camera into CloudLync by PC & Notebook

3.2.1 Binding Camera for the First Time

At this stage, you already have your personal account registered with CloudLync but with no camera attached to your account. So the next step is to bind the camera that you have just set up into your new CloudLync account in order to establish link with the network.

Step 1. After clicking the hypertext **“Please click to verify your registration”** under **Create Account**, or clicking the **Sign in** button under **Google Account**, the “Connect IP camera” window (shown at right) will pop-up after confirming your name and password. This is to remind you again to properly connect the camera to power and router. If connection is okay, click the **Next** button.

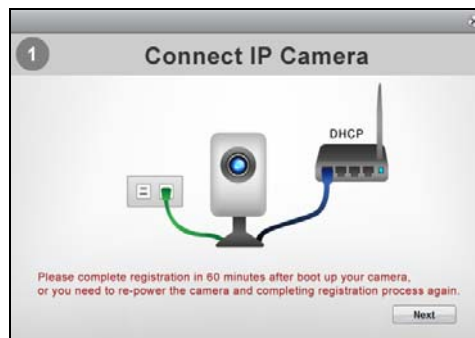

Step 2. The “Bind IP Camera” windows will pop-up to remind you to get ready with your camera’s MAC Address and Activate Code. Then click the **Next** button.



Step 3. The **Binding** dialog will then display to prompt you to provide the camera's MAC address and Activate Code (serial number).

No.	MAC Address	Activate Code	Apply
1	<input type="text"/>	<input type="text"/>	<input type="button" value="Apply"/>
2	<input type="text"/>	<input type="text"/>	<input type="button" value="Apply"/>
3	<input type="text"/>	<input type="text"/>	<input type="button" value="Apply"/>
4	<input type="text"/>	<input type="text"/>	<input type="button" value="Apply"/>
5	<input type="text"/>	<input type="text"/>	<input type="button" value="Apply"/>
6	<input type="text"/>	<input type="text"/>	<input type="button" value="Apply"/>
7	<input type="text"/>	<input type="text"/>	<input type="button" value="Apply"/>



Note

1. The required data are available from the QR Code Activation Card.
2. These numbers are unique for each camera.



Step 4. After the MAC Address and Activate Code are entered, click the **Apply** button at the right end of the row and the button position will switch from **“Apply”** to **“Success”** to indicate successful binding of the camera with CloudLync as illustrated below.

No.	MAC Address	Activate Code	Apply
1	<input type="text" value="00304f034466"/>	<input type="text" value="PLANETPLANET"/>	Success
2	<input type="text"/>	<input type="text"/>	<input type="button" value="Apply"/>
3	<input type="text"/>	<input type="text"/>	<input type="button" value="Apply"/>
4	<input type="text"/>	<input type="text"/>	<input type="button" value="Apply"/>
5	<input type="text"/>	<input type="text"/>	<input type="button" value="Apply"/>
6	<input type="text"/>	<input type="text"/>	<input type="button" value="Apply"/>
7	<input type="text"/>	<input type="text"/>	<input type="button" value="Apply"/>



Note

If error occurs, an error message is displayed to the right end of the MAC address value as shown below.

No.	MAC Address	Activate Code	Apply
1	<input type="text" value="00304f034466"/> Invalid activation code.	<input type="text" value="PLANETPLANET"/>	<input type="button" value="Apply"/>
2	<input type="text"/>	<input type="text"/>	<input type="button" value="Apply"/>
3	<input type="text"/>	<input type="text"/>	<input type="button" value="Apply"/>
4	<input type="text"/>	<input type="text"/>	<input type="button" value="Apply"/>
5	<input type="text"/>	<input type="text"/>	<input type="button" value="Apply"/>
6	<input type="text"/>	<input type="text"/>	<input type="button" value="Apply"/>
7	<input type="text"/>	<input type="text"/>	<input type="button" value="Apply"/>

Step 5. After successful binding, click the **Close** button at the top-right corner. The **Setting Table** then displays.

Name	Owner	MAC Address	Service Type	Port	Device Matrix	Config
00304FA9CFF3	brandonwa...	00304FA9CFF3	Camera	554	<input checked="" type="checkbox"/>	

Items Per Page: 20 | 1 / 1

Matrix | Setting

Step 6. Click the **Matrix** button at the bottom of the window to display the live view camera surveillance.

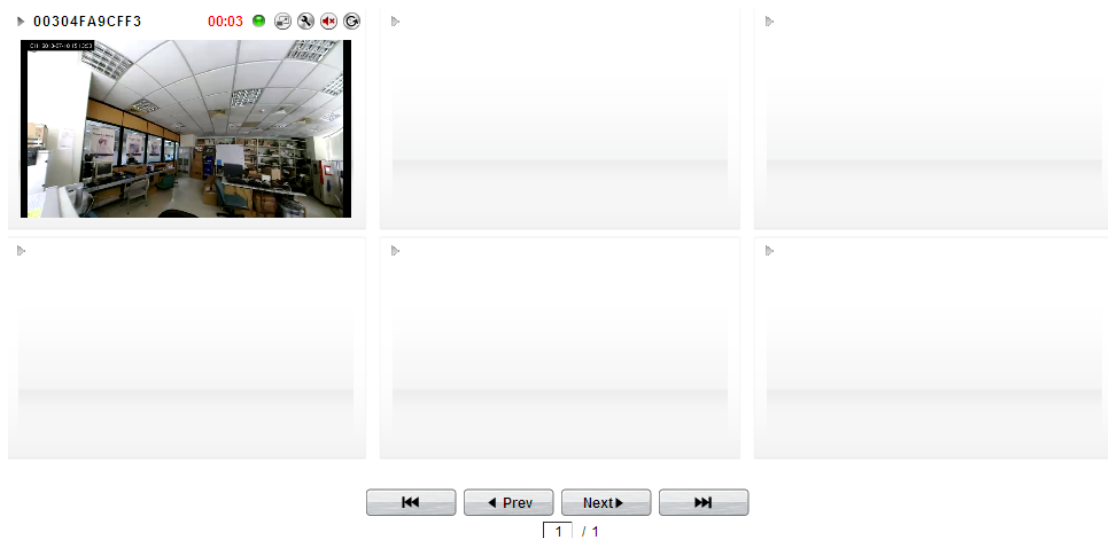

Step 7. Click the **Full Screen** button to zoom and view the live display in full screen.

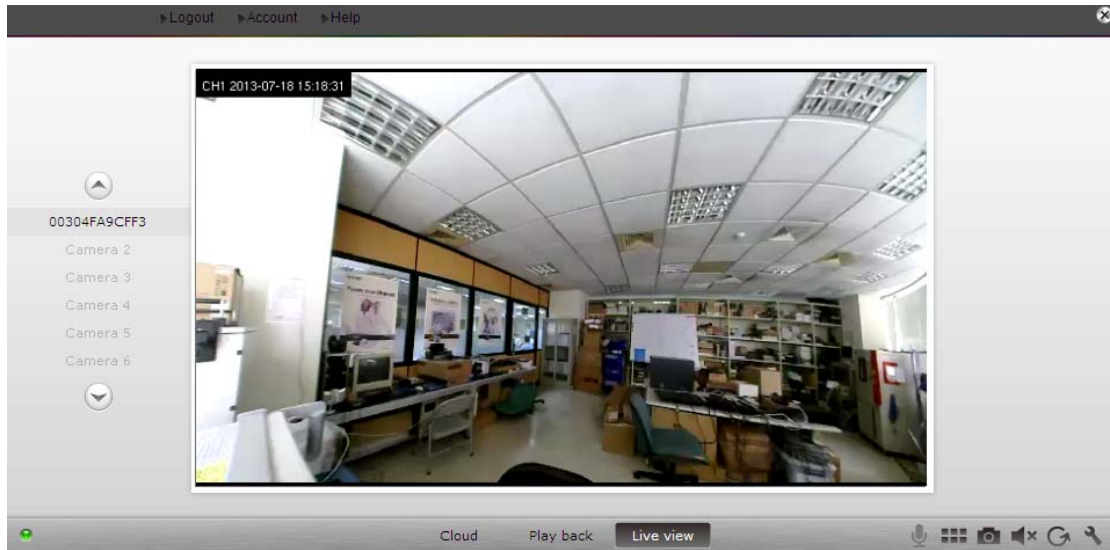



3.2.2 Modifying Camera Default Names

With several cameras being installed, you may have a hard time identifying which camera is installed with this MAC address. Hence, you may assign unique names to each camera for easy identification, such as names that are related to camera positions. To do so, carry out the following steps.

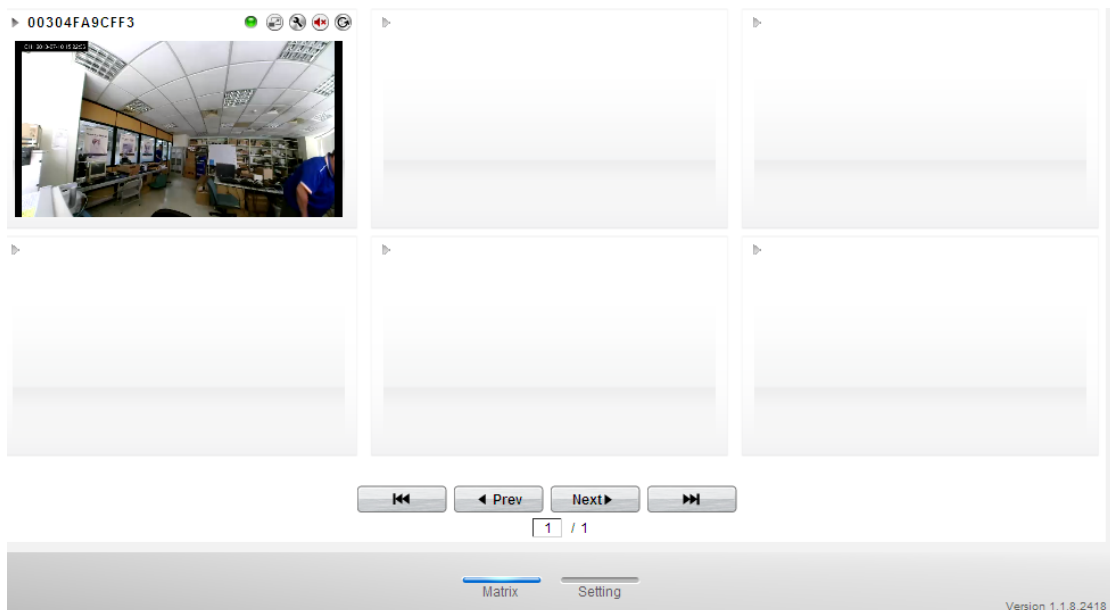
Step 1. From the bottom of the **Matrix** Window, click the **Setting** button.



Step 2. When the camera **Setting** table appears (illustrated below), click on the **Setting** button of the camera you want to change name.

		Account		Device		
Name	Owner	MAC Address	Service Type	Port	Device Matrix	Config
00304FA9CFF3	brandonwa...	00304FA9CFF3	Camera	554	<input checked="" type="checkbox"/>	 

Step 3. The **Modify** dialog will then appear as illustrated below. Click on the **Name** text box to enter a new camera name. You can also change video by clicking on the Video Quality option buttons. Then click **Apply** button to execute the changes.

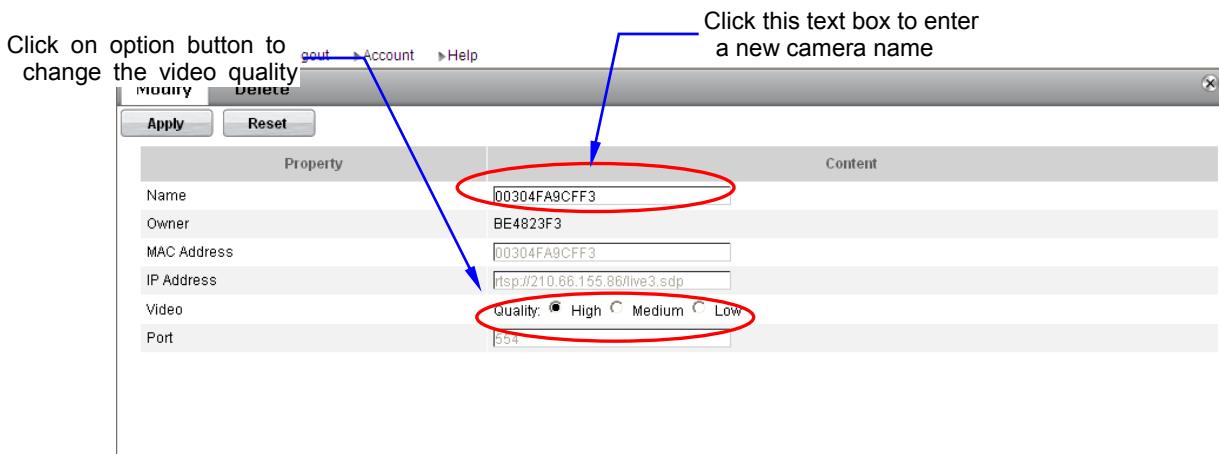

3.3 CloudLync Account Registration by Smartphone & Tablet

3.3.1 Downloading CloudLync App

Download CloudLync App from App Store or Google Play Store by your iPhone or Android phone by searching “CloudLync” as the key word.

Alternatively, you may scan the QR Code below with your device to automatically download URL and “CloudLync App” into your Smartphone/tablet.



3.3.2 CloudLync Registration through “Create Account”

Step 1. From your device apps display, tap the “CloudLync App” icon to launch CloudLync. When the following dialog displays, tap the **Create Account** button to create or register your new CloudLync account.

(iPhone/iPad Display)

(Android Mobile Display)

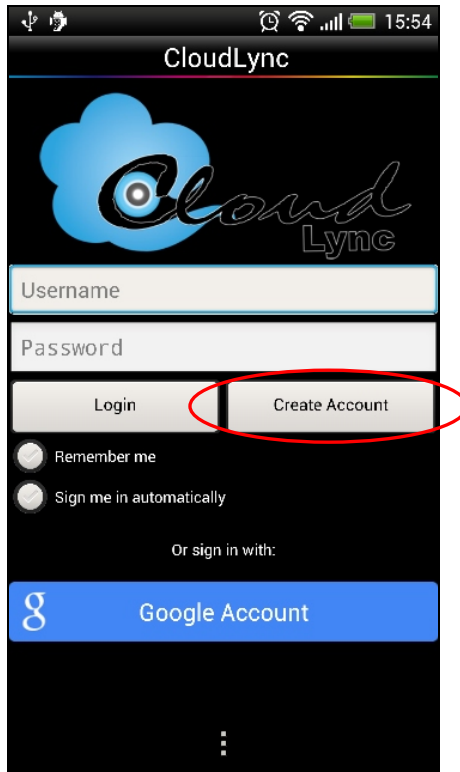

Step 2. When the **CloudLync Create Account** dialog pops-up, enter the required information in the text boxes.

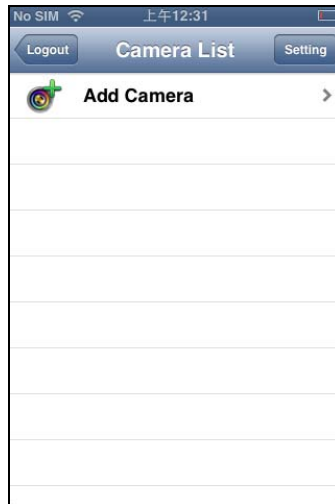

Step 3. Tap **Apply** button to start binding your camera.

3.3.3 CloudLync Registration through “Google Account”

Step 1. If you already have a Google account, you can tap the **Google Account** button to register with CloudLync.

(iPhone/iPad Display)

(Android Mobile Display)

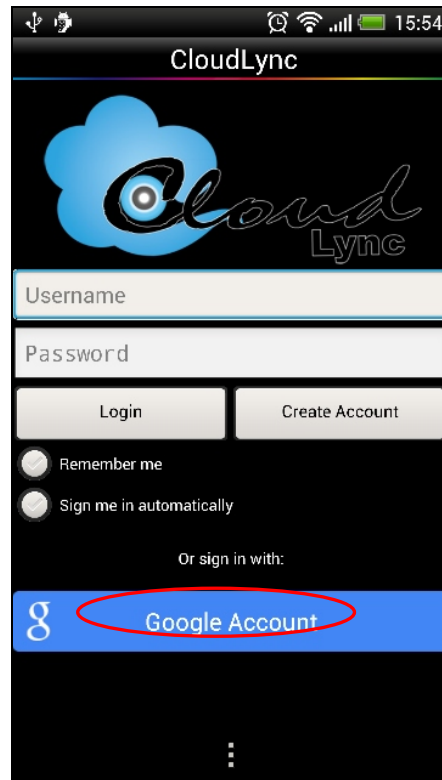

Step 2. When the Google **SIGN UP** dialog (see below) pops-up, enter the required information in the text boxes.

Step 3. Tap **Sign In** button to start binding your camera

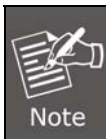
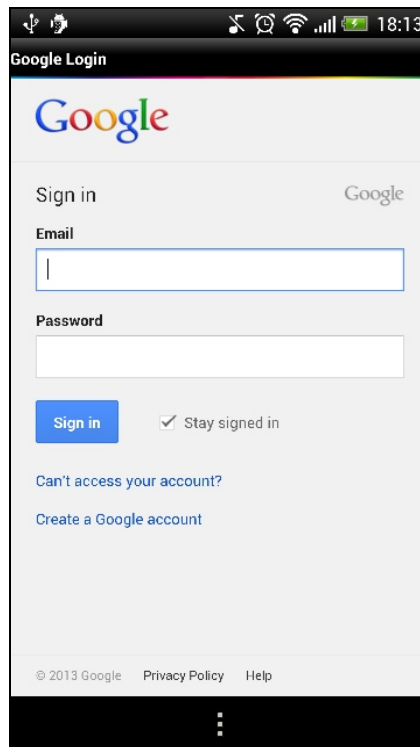

1. Google Account provides 5GB free space for recorded video storage.
2. If "Google Account" is used to create the CloudLync account, you have to use your Gmail address as email address and tap the "**Google Account**" button every time you need to log-in into CloudLync again.

3.4 Binding Camera into CloudLync by Smartphone & Tablet

With CloudLync account successfully implemented, the **Camera List** dialog will display to prompt you to start binding your new camera(s) to CloudLync by following the process described below:

Step 1. Tap the **Add Camera** button

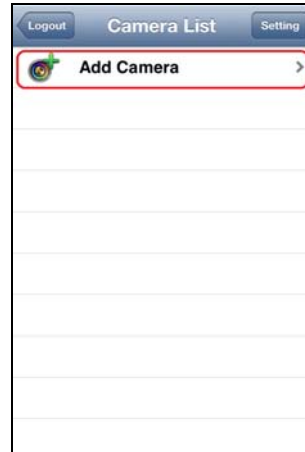

Step 2. Tap the **Next** button if the camera connection is okay.



Step 3. “Bind IP Camera” window pops-up to prompt for MAC Address and Activate Code input into CloudLync. This is done by either scanning the unique QR Code card, or by manually keying in the data.

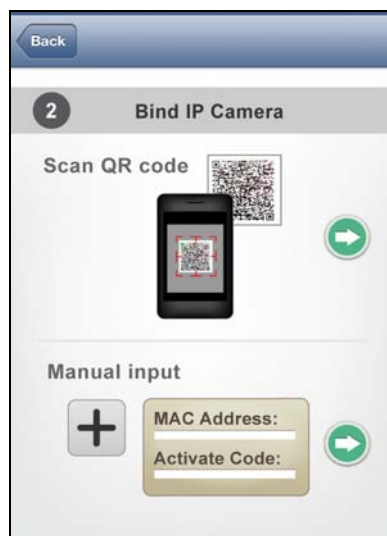

Step4. The MAC Address (serial number) of the new camera is now being added to the existing list. Tap the serial number to view the camera on-line.

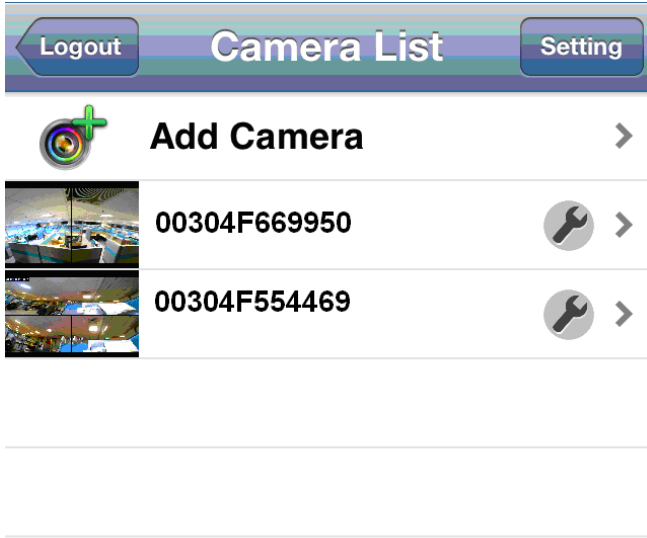

Step 5. Live on-line video is now on display.

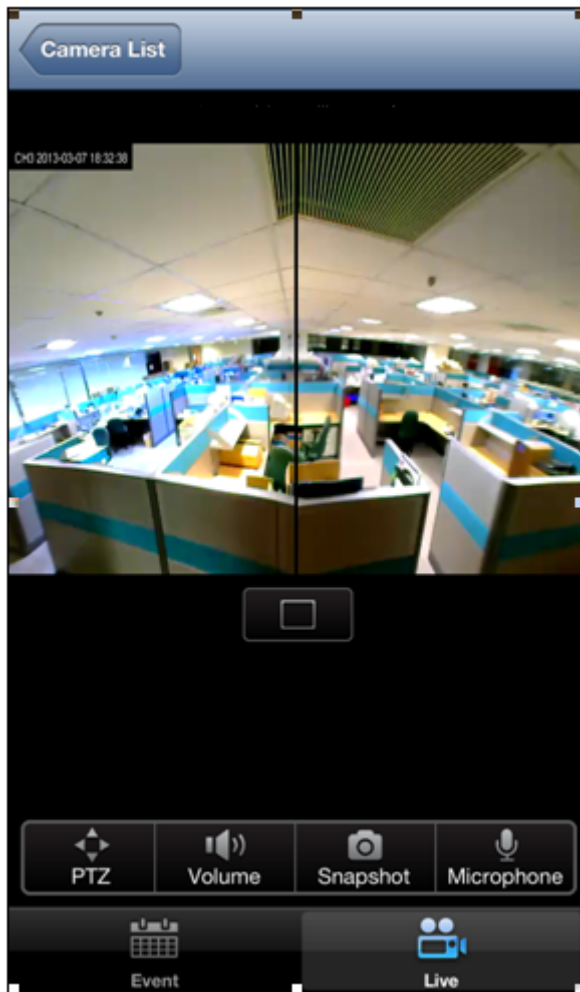

 **Note** You cannot use your Smartphone to change the camera default designation. You need to use a PC/notebook/Ultrabook to accomplish it.

Chapter 4. Web-based Management

This chapter provides setup details of the Internet camera's Web-based Interface.

4.1 Introduction

The Internet camera can be configured with your Web Browser. Before configuring, please make sure your PC is under the same IP segment with Internet camera.

4.2 Connecting to Internet Camera

- A. Use the following procedures to establish a connection from your PC to the Internet Camera.
- B. Once connected, you can add the camera to your Browser's Favorites or Bookmarks.

Start the web browser on the computer and type the IP address of the camera.
The Default IP: "<http://192.168.0.20/>"

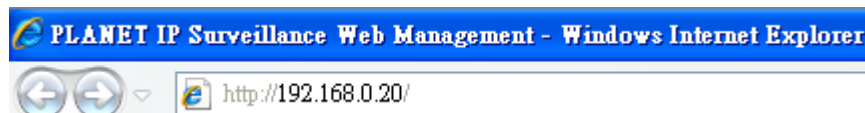

The login window of Internet camera will appear,
Default login **username** and **password** are: **admin** and **admin**

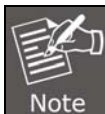
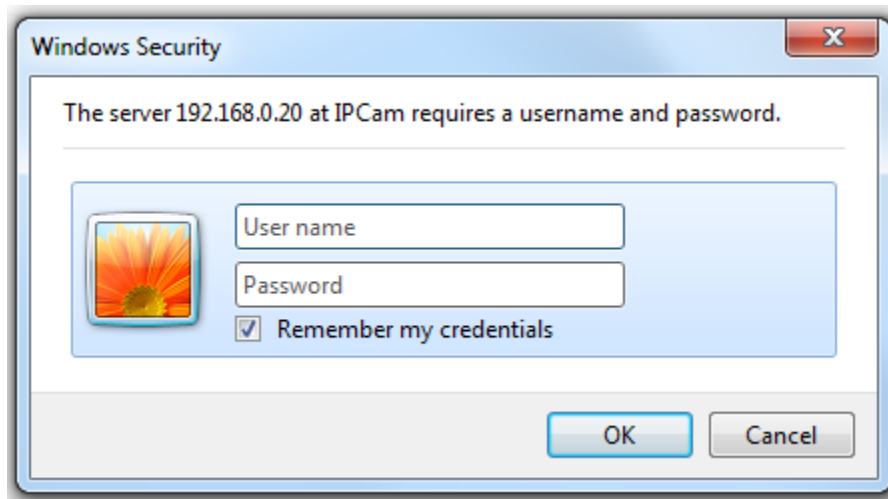

If the User Name and Password have been changed with PLANET IPInstaller, please enter the new User Name and Password here.

After logging on, you should see the following messages at the top of Internet Explorer:

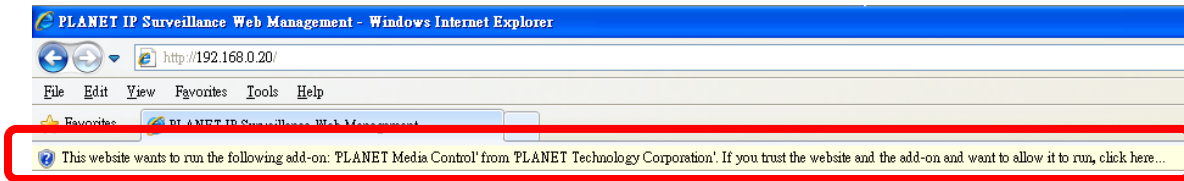

Click on the message, and click **Run Add-on**

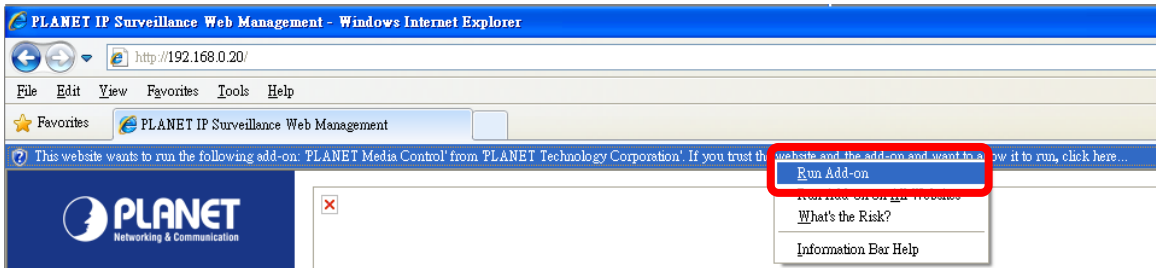

When you see this message, click **Run** to install required ActiveX control



After the ActiveX control is installed and run, the first image will be displayed.











You should be able to see the images captured from the Internet camera on the web page now. For advanced functions, please refer to instructions given in the following chapters.



 Note	If you log in the camera as an ordinary user, setting function will be not available. If you log in the camera as the administrator, you can perform all the settings provided within the device.
---	---

4.3 Live View

Start-up screen will be as follows no matter you are an ordinary user or an administrator.

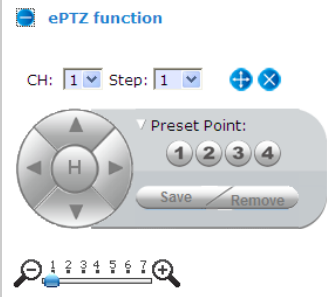

Button	Description						
<p>Display Mode</p>  <p>Actual Size (640x360)</p> <p>Protocol: TCP</p> <p>Video Stream: 1</p>	<p>With its fisheye lens (180° wide angle panoramic view), the Camera can offer the following live view display modes:</p> <table border="1" data-bbox="609 997 1291 1207"> <tr> <td></td> <td>180 degree Ultra Wide Angle View</td> </tr> <tr> <td></td> <td>Twin PTZ (pan-tilt-zoom) Views</td> </tr> <tr> <td></td> <td>Triple views (1 Ultra Wide Angle View + Twin PTZ View)</td> </tr> </table> <p>When the Twin or Triple PTZ display mode is selected, click the ePTZ function tool to display the PTZ setting tools.</p> <p>Protocol: Option for TCP or UDP transmission protocol with H.264/MPEG4/MJPEG streaming is available.</p> <p>Video Stream: Two simultaneous streaming is supported for live viewing.</p>		180 degree Ultra Wide Angle View		Twin PTZ (pan-tilt-zoom) Views		Triple views (1 Ultra Wide Angle View + Twin PTZ View)
	180 degree Ultra Wide Angle View						
	Twin PTZ (pan-tilt-zoom) Views						
	Triple views (1 Ultra Wide Angle View + Twin PTZ View)						
	<p>CH: Select the PTZ channel or display window (1 or 2) to implement PTZ setting.</p> <p>Step: Adjust and set the speed of live view panning motion.</p> <p>Directional Buttons: Use to manually pan the scene to select and zoom a specific area (1 of 4 maximum) to be monitored. To reset the scene back to its previous status, click the center Home (H) button. You can also directly click on the video to pan, zoom, and tilt a selected area.</p> <p>Preset Point: After panning and zooming, assign the selected area a Preset Point (1 to 4) and click Save button to store the setting. The pre-defined point of view areas will be monitored in sequence. To cancel the selection, click Remove button.</p> <p>Zoom Slider: Drag slider to zoom-in and zoom-out the selected scene. Zoom setting is saved with the selected pre-defined point of view area.</p>						

<p>Recording Path</p> <input type="text" value="C:\Documents and Settings\brandonw"/> <p>Recording file name</p> <input type="text" value="66"/> <p>Browse</p> 	<p>Click Browse button to define Recording Path and Recording Filename for the video you are preparing to record.</p> <p>Recording Path: Specify a storage destination path for the video you are going to record.</p> <p>Recording file name: Define a base filename for the video recordings you are going to take. The base filename will auto-expand for each saved video recording.</p> <p>To start recording, click the Recording button.</p>
<p>Snapshot Path</p> <input type="text" value="C:\Documents and Settings\brandonw"/> <p>Snapshot file name</p> <input type="text" value="99"/> <p>Browse</p> 	<p>Click Browse button to define Snapshot Path and Snapshot Filename for the snapshots you are preparing to capture.</p> <p>Snapshot Path: Specify a storage destination path for the snapshot images you are preparing to capture.</p> <p>Snapshot file name: Define base filename for the snapshots you going to capture. The base filename will auto-expand for each saved snapshot.</p> <p>To start capturing snapshots, click the Snapshot button.</p>
<p>Setting Language</p> <input type="text" value="English"/> 	<p>Setting Language: Select the default language of the user-interface.</p> <p>Setup: The Setup dialog will then display to provide the range of setup categories you will be able to change.</p>

4.4 System Configuration

Clicking the **System** button will display the following tabbed panes relative to system configurations.

4.4.1 Information Tab

Information
Time
Security
Maintenance

System Information

Model Name:	ICA-W8100
System Time:	2013/07/22 11:15:44
Firmware Version:	1.0.0_0712
MAC Address:	00:30:4f:a9:cf:f3
ActiveX control version:	0.0.5.3

Wired network

Status:	Connected
Mode:	STATIC
IP Address:	192.168.1.32
Subnet Mask:	255.255.255.0
Gateway:	192.168.1.254
Primary DNS:	168.95.1.1
Secondary DNS:	0.0.0.0

Wireless network

Status:	No connection
MAC Address:	00:12:0e:ff:ea:ca
Mode:	DHCP
IP Address:	0.0.0.0

The information tabbed pane provides the existing system status of the camera which includes Model Name, System Time, Firmware Version, MAC Address, ActiveX Control Version, Wired Network, Wireless Network and DDNS Server Status.

4.4.2 Time Tab

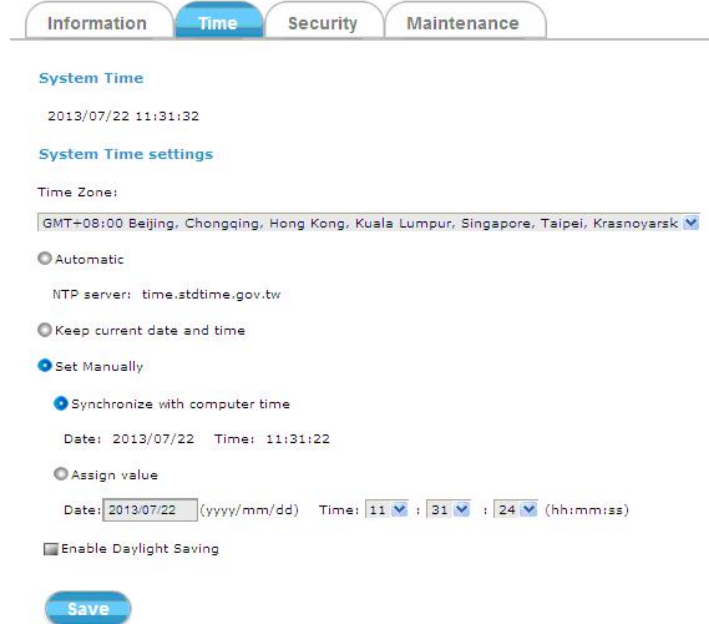

The **Time** tabbed pane is where you set up the clock of your Camera to synchronize with your local time. Where:

System Time	The Network camera current date and time is applied and displayed here based on the setup status of the System Time Settings as detailed below.
Time Zone	Select the applicable Time Zone of your city in reference to Greenwich Mean Time.
Automatic	Select this item if you want to automatically synchronize the camera clock with that of Network Time Protocol (NTP) Server.
Keep current date and time setting	Select this option in lieu of automatic synchronization if the camera is not connected to NTP Server and uses its own embedded clock.
Set Manually	<p>Synchronize with the PC Time: Select this option to manually synchronize the Network Camera clock (date and time) with that of the local host computer.</p> <p>Assign value: Select this option to enter the date and time manually.</p>
Enable Daylight Saving	Select this option only when applicable at your location. Two setup settings; the Start time and End time are needed to implement the feature.

4.4.3 Security Tab



The **Security** tabbed pane allows you to add new camera User Name and change Password and the surveillance status or User Group. Click the **ADD** button to access the security setup dialog (shown below).

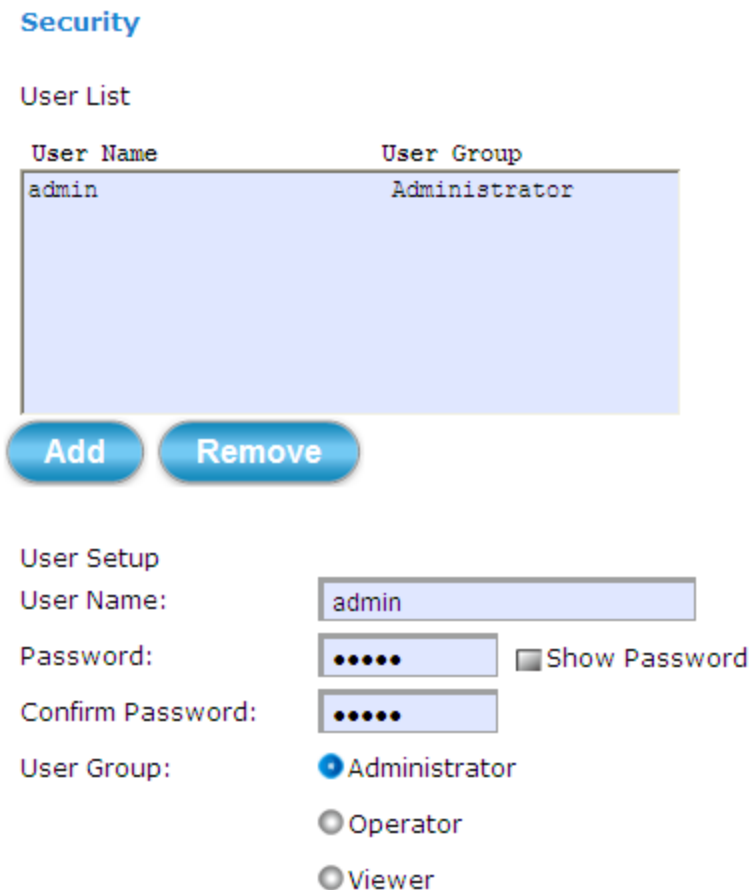

User Name	Enter the new user name to be added into the list (see Note 4 of dialog for proper entry).
Password	Enter the new password (see Note 4 of dialog for proper entry).
Confirm password	Enter the password again for authentication (encoded display).
Show Password	Displays the decoded password when check box is enabled.
User Group	<p>Three group options are available, namely:</p> <p>Administrator: User is allowed to change camera settings and perform all camera functions.</p> <p>Operator: User is allowed to login “Live View” Webpage and perform all functions within this page. Except changing video and audio settings of camera live stream, other adjustments of camera parameter are prohibited.</p> <p>Viewer: User is only allowed to login “Live View” Webpage and perform all functions within this page. Changing camera settings is prohibited.</p>

4.4.4 Maintenance Tab

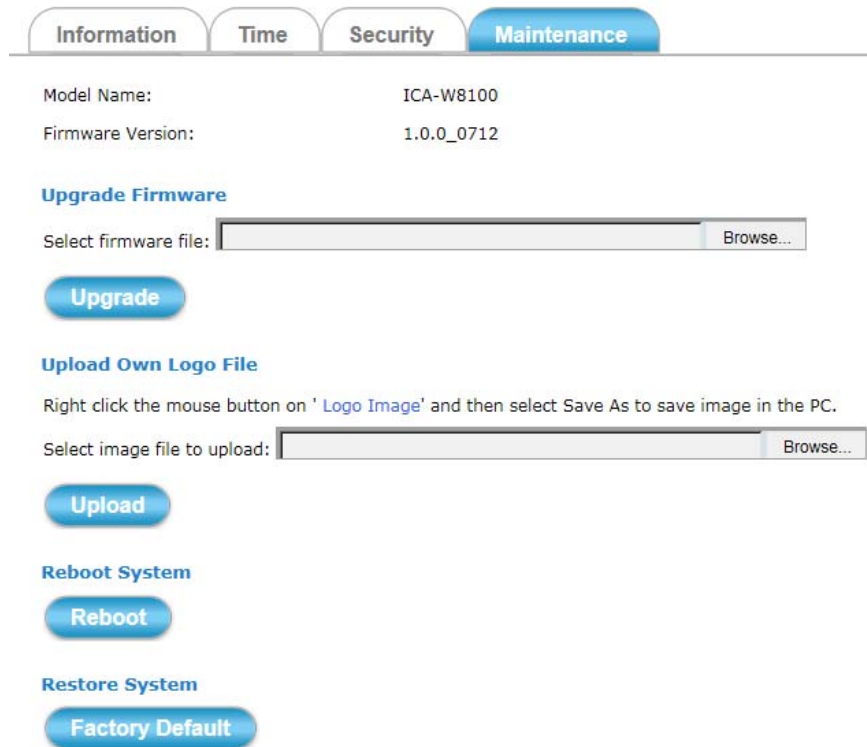

The screenshot shows the 'Maintenance' tab selected. It contains the following elements:

- Information:** Model Name: ICA-W8100; Firmware Version: 1.0.0_0712
- Upgrade Firmware:** A text input field for 'Select firmware file:' with a 'Browse...' button, followed by an 'Upgrade' button.
- Upload Own Logo File:** Instructions to right-click on 'Logo Image' and select 'Save As'. A text input field for 'Select image file to upload:' with a 'Browse...' button, followed by an 'Upload' button.
- Reboot System:** A 'Reboot' button.
- Restore System:** A 'Factory Default' button.

The **Maintenance** tabbed pane allows you to upgrade the firmware with the latest version and to restore the Network camera settings to factory default.

Select firmware file

Download the latest firmware file from the website by executing the following steps:

- 1) Click the **Browse** button to access and select the appropriate firmware file from its folder.
- 2) Click the **Upgrade** button. The Network camera will then start to upgrade the existing firmware. When upgrade is completed, the camera will reboot automatically.

Reboot System

Clicking the **Reboot** button allows you to manually reboot the Network camera.

Restore System

Clicking the **Factory Default** button will restore the Network camera to its factory default settings status. Before camera system proceeds to restore step, there'll be a dialog window popped and then ask if you would like to let the following three settings remain current:

- Network setting
- Username/Password
- System clock (time & date)

4.5 Network Setup Execution

Clicking the **Network** button will display the following tabbed panes on configuring camera connection with the network.

4.5.1 General Tab

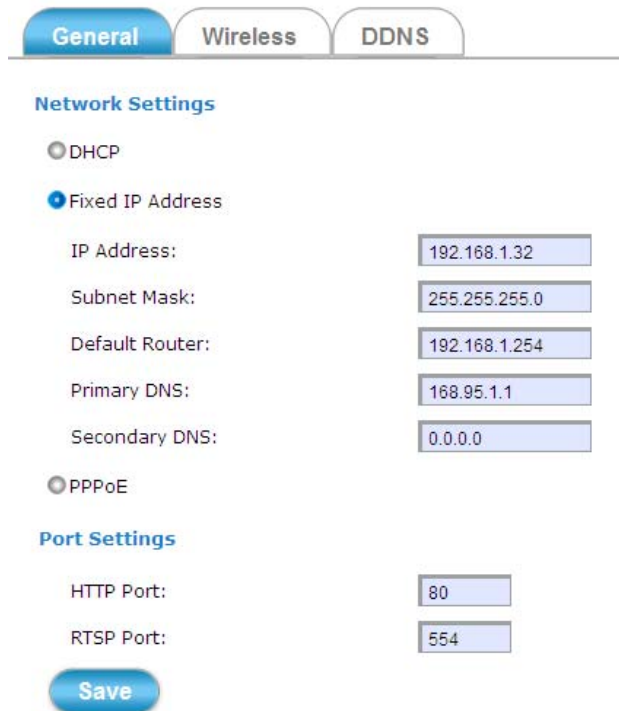

The screenshot shows the 'General' tab of the 'Network Settings' configuration page. At the top, there are three tabs: 'General' (selected), 'Wireless', and 'DDNS'. Below the tabs, the 'Network Settings' section has two radio buttons: 'DHCP' (unselected) and 'Fixed IP Address' (selected). Under 'Fixed IP Address', there are six input fields: 'IP Address' (192.168.1.32), 'Subnet Mask' (255.255.255.0), 'Default Router' (192.168.1.254), 'Primary DNS' (168.95.1.1), and 'Secondary DNS' (0.0.0.0). Below this, there is a radio button for 'PPPoE' (unselected). The 'Port Settings' section has two input fields: 'HTTP Port' (80) and 'RTSP Port' (554). At the bottom, there is a blue 'Save' button.

The **General** tabbed pane (shown above) allows you to redefine the network and port protocol settings of the Network camera.

DHCP This option obtains the available dynamic IP address assigned by the DHCP server each time the camera is connected to the network.

Fixed IP Address This option manually assigns a static IP address to the Network camera.

PPPoE Select this option to set PPPoE account & password.

PPPoE

PPPoE User Name:

PPPoE Password:

Recipient E-mail Address: (ex: rcpt@mail.com)

SMTP E-mail Server: (ex: mail.examples.com or 192.168.1.1)

SMTP Port: (0..65535)

SMTP user name:

SMTP Password:

Sender E-mail Address: (ex: from@mail.com)

Use SSL-TLS: ▼

Test E-mail

Port Settings

HTTP Port:

RTSP Port:

Save

While PPPoE protocol is selected, you may have to enter some more information such as the above picture.

While camera IP is changed dynamically because of PPPoE Network connection, its new IP Address will be sent to “Sender E-mail Address” through SMTP service. So you won’t worry about the difficulty in camera’s Webpage access.

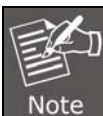
 **Note** As for the settings of SMTP service, kindly please contact your e-mail service provider. After you confirm all parameters are correct and working properly, you may enter them into the text area manually.

Port Settings:

HTTP Port: Re-define the existing HTTP Port number in the text box.

RTSP Port: Re-define the existing RTSP Port number in the text box.

4.5.2 Wireless Tab

General
Wireless
DDNS

Status of Wireless Networks

SSID	Mode	Security	Signal strength
PlanetAP	Infrastructure	WPA2-PSK	86
VRT-420N	Infrastructure	WPA2-PSK	71
HTC Portable Hotspot	00:30:4f:ce:94:63 Infrastructure	WPA2-PSK	60
ADN-4100	Infrastructure	NONE	96
RTK 11n AP 2.4G	Infrastructure	NONE	96

Refresh

Wireless Settings

Wireless Connection: Enabled Disabled

MAC Address: 00:12:0e:ff:ea:ca

IP Setting Mode: DHCP Service Static IP Address

IP Address: 0.0.0.0

Netmask: 0.0.0.0

Gateway: 0.0.0.0

Mode: Infrastructure ▼

SSID: 12345678

The **Wireless** tabbed pane provides search and display of available wireless networks from which you can select the most suitable one for your camera.

Status of Wireless Networks Displays the list of wireless networks (access points) currently available; grouped under SSID, Mode, Security, and Signal Strength categories. Click the **Refresh** button to refresh the list for possible additional list of wireless networks not previously available.

Wireless Setting Defines the configurations to enable the camera to connect to the selected wireless network. Clients in the same network group are able to access to this camera through wireless connection.

WPA-PSK Setting Defines the Wi-Fi Protected Access setting in Pre-Shared Key mode relative to the selected wireless network.

4.5.3 DDNS Tab

General
Wireless
DDNS

Dynamic DNS Setting 1

DDNS Enable

DDNS option: Planet Easy DDNS ▾

Easy Domain Name: pla9cff3.planetddns.com

Status: No connection

Save

Dynamic DNS Setting 2

DDNS Enable

Host name: hostname
(ex: ddns.test.com)

[Link to http://www.dyndns.org](http://www.dyndns.org)

User Name: username

Password: ●●●●●●

Show Password

Update Time: 1000 (600~86400 Seconds)

Status: No connection

The **DDNS** tabbed pane allows you to configure the Dynamic Domain Name System of your network device with a host name instead of the IP Address.

DDNS Enable	Enable the check box to support DDNS function. This model adds Planet easy DDNS that when this function enable will occur hostname with PLANET DDNS and end six of MAC automatically. User don't go to web of www.planetddns.com apply new account.
Host Name	Enter the Host name which you registered and got through DNS Service Provider. The assigned host name is used to access the network device instead of IP Address.
User Name/Password	Account authentication for logging into the website of DNS Service Provider.

Update Time Define a time interval for the device to periodically update and check its access status with website of DNS Service Provider.

4.6 Video & Audio Setup Execution

Clicking the **Video & Audio** button will display the following tabbed panes for defining camera streaming, video, and audio functions.

4.6.1 Stream Tab

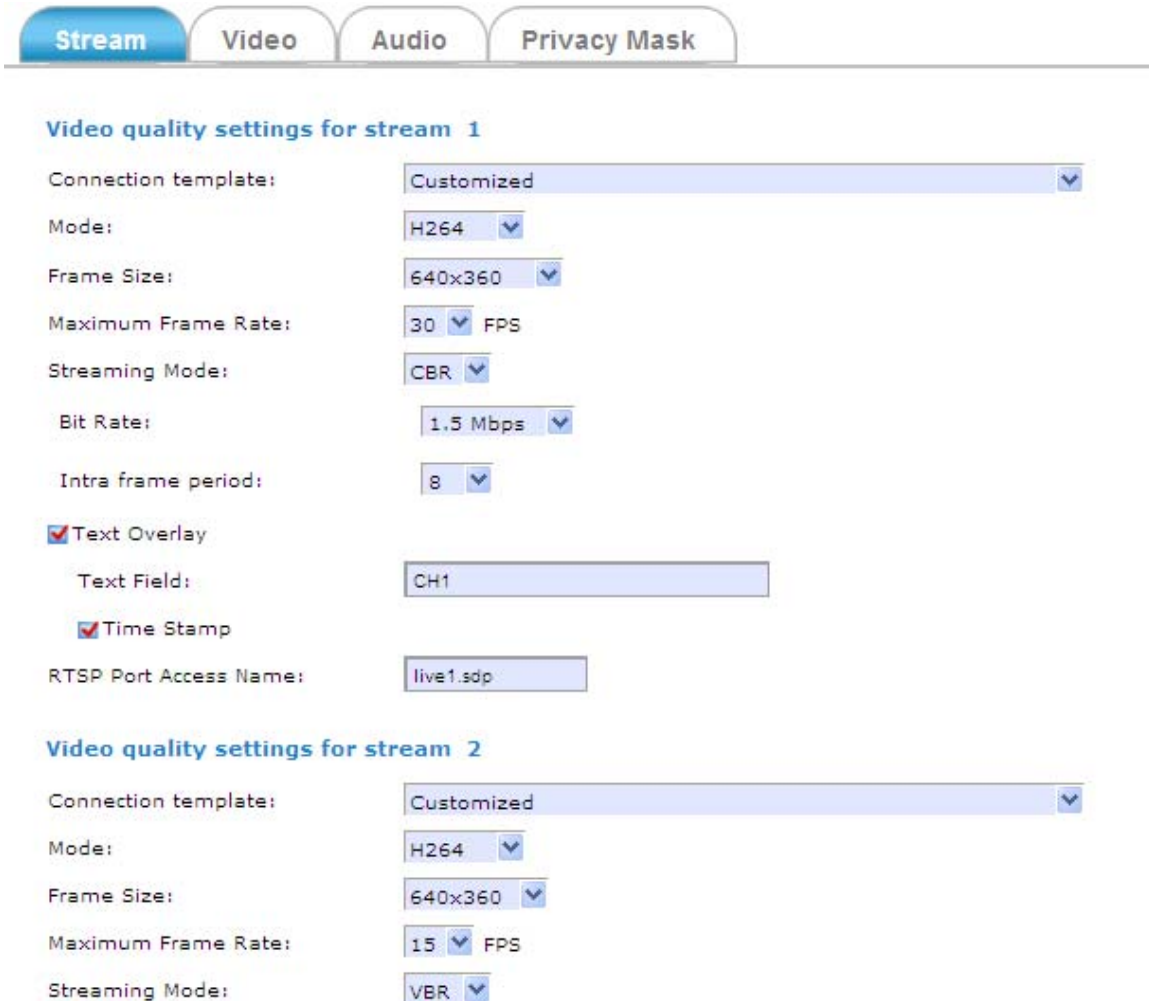

Stream Video Audio Privacy Mask

Video quality settings for stream 1

Connection template: Customized

Mode: H264

Frame Size: 640x360

Maximum Frame Rate: 30 FPS

Streaming Mode: CBR

Bit Rate: 1.5 Mbps

Intra frame period: 8

Text Overlay

Text Field: CH1

Time Stamp

RTSP Port Access Name: live1.sdp

Video quality settings for stream 2

Connection template: Customized

Mode: H264

Frame Size: 640x360

Maximum Frame Rate: 15 FPS

Streaming Mode: VBR

Quality:

Intra frame period:

Text Overlay

Text Field:

Time Stamp

RTSP Port Access Name:

Video quality settings for stream 3

Connection template:

Mode:

Frame Size:

Maximum Frame Rate: FPS

Streaming Mode:

Quality:

Intra frame period:

Text Overlay

Text Field:

Time Stamp

RTSP Port Access Name:

The **Stream** tabbed pane (see above figure) provides the adjustments for the video quality of the camera streaming function. The pane offers the following three modes of video quality setting:

Connection Template	Four option modes are available: “Fast,” “General,” “Low,” and “Customized” modes.
Mode	Three modes of encoding options are offered: “H264,” “MPEG4”, and “MJPEG”.
Frame Size	Three 3 types of streamed frame resolutions are available for selection: “1280x720”, “640x360”, and “320x180”.
Maximum Frame Rate	Available rate options are: 5, 8, 10, 15, 20, 25, & 30 frames per second (FPS).
Steaming Mode	Two choices of streaming modes are offere; “VBR (variable bit rate)” and “CBR (constant bit rate)”.

Quality The options for streaming mode quality are expressed differently between VBR and CBR:

VBR: Standard, Good, & Detailed

CBR: 64Kbps, 128 Kbps, 256 Kbps, 384 Kbps, 512 Kbps, 768 Kbps, 1M Kbps, 1.5M Kbps

Intra Frame Period Available choices are: 5, 8, 10, 15, 20, 25, 30, 40, 50 & 60 frames per period. This function will let you choose how long distance between two I-Frames.
Larger value means longer distance between two I-Frames and this selection is suitable for the stable Network Bandwidth Environment; so we suggest the smaller value selection is proper to the worse Network Bandwidth Environment.

Text Overlay When enabled, each streamed frame will be overlaid with the Camera ID (text field) and stamped with date/time (if enabled) as illustrated below.

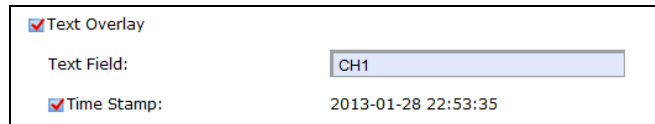

The screenshot shows a control panel for text overlay. It includes a checked checkbox for "Text Overlay", a "Text Field:" label with an input box containing "CH1", and a checked checkbox for "Time Stamp:" with a timestamp of "2013-01-28 22:53:35".

RTSP Port Access Name When RTSP or VLC media-player is used, the port can be renamed with easy to remember pathname.
For example, the default RTSP Port Access Name is live1.sdp; it means your playback stream name would be **"RTSP://camera's IP address/live1.sdp"**

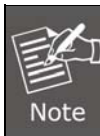
 **Note** If the "Video Event Alarm Setting by Video" is enabled, an alert message will display requiring you to disable the feature first before proceeding to change the Streaming settings. Otherwise, adjustments to video quality streaming settings **cannot** be accomplished.

4.6.2 Video Tab

Stream
Video
Audio
Privacy Mask



Video Settings

Brightness: 80 (0~255)

Saturation: 80 (0~255)

Contrast: 0 (-128~127)

Color/Mono Mode: Auto Color Mono

Day / Night Threshold: 10 (5~100)

Power Line Frequency: 50 Hz 60 Hz

Video Orientation: Flip Mirror

LED Status: On Off

PIR LED: On Off

The **Video** tabbed pane lets you to perform live adjustments and improvement of the camera captured video effect relative to the target environment. If you experience difficulty in implementing the adjustment parameters, it is recommended that you use the default setting by pressing the **Reset** button (see figure below) at the back of the camera.

Brightness	The luminance of the captured image apart from its hue or saturation.
Saturation	The degree of intensity and purity of a specific color.
Contrast	The brightness ratio of the lightest to the darkest part of the video image.
Day/Night Threshold	Set the illumination lux value (5 ~ 100) to auto-trigger the camera into “day” or “night” mode relative to luminance of the area under surveillance. When the environment luminance becomes higher than the set lux value, the camera will auto switch to “day” or “color” mode. Otherwise, it will remain at “night” or “mono” mode.

4.6.3 Audio Tab

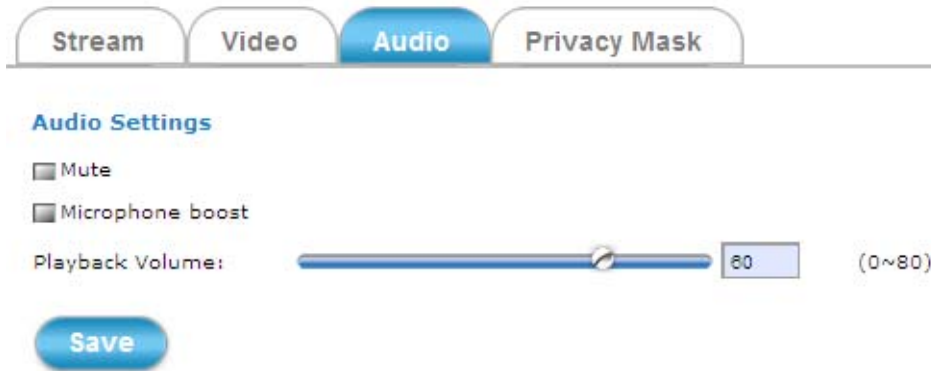

The **Audio** tabbed pane provides the following audio adjustments to your camera microphone and speaker:

Mute	Enable or disable mute function of the camera microphone.
Microphone boost	Enable or disable booster function of the camera microphone. Enable this function will amplify the signal from the microphone jack.
Playback Volume	Adjust the camera speaker volume by moving the slider to the left to decrease and to the right to increase the volume.

4.6.4 Privacy Mask Tab

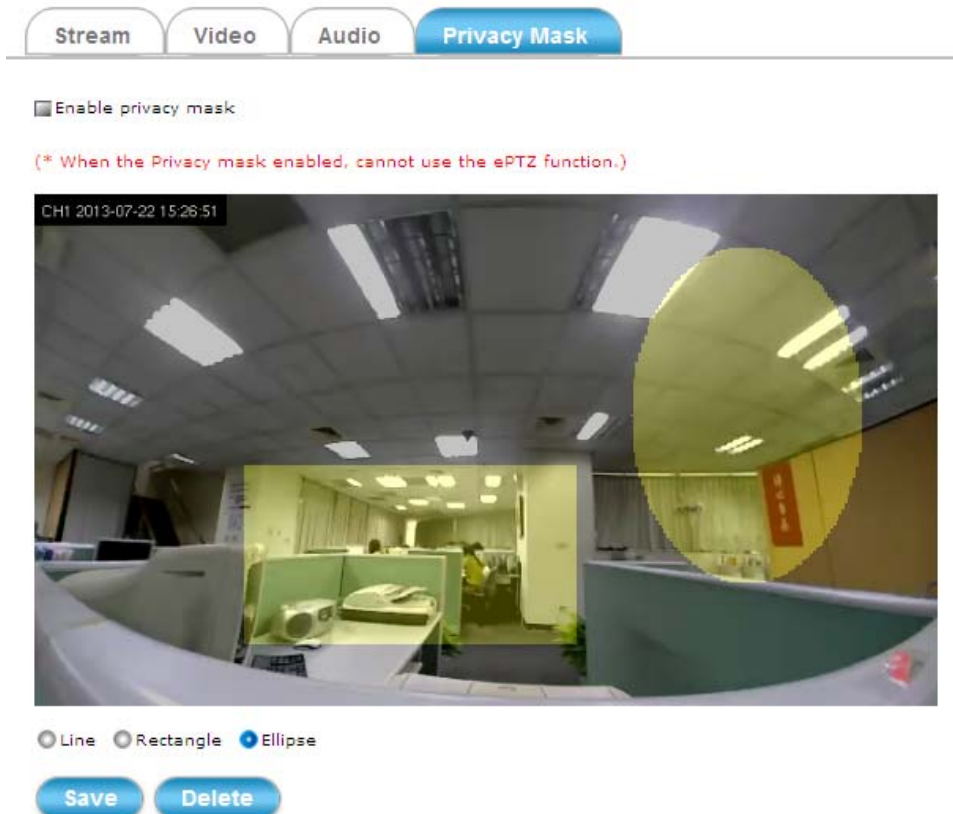

The **Privacy Mask** tabbed pane allows you to mask or block private areas from surveillance for privacy reason.

■ To block a private area from surveillance, follow the procedure below:

Step 1. Initially select the masking shape, e.g., “Line,” “Rectangle,” or “Ellipse” you wish to use as screen to block the area from surveillance.

Step 2. Click and drag the mouse cursor to lay out a masking screen on the area you wish to block, and then release the mouse right button. Notice that the laid out screen turns into phantom block.

Step 3. If the laid out screen needs correction, click **Delete** button and redo the masking screen lay out process.

Step 4. Once the masking screen is acceptable, click the **Enable Privacy Mask** check box followed by clicking of the **Save** button. This will turn the laid out screen into solid block.

■ To disable masking and remove the screen, do the following:

Step 1. Click **Delete** button.

Step 2. Click **Save** button and wait a while. Then the screen is permanently removed.

Step 3. To permanently disable the **Privacy Mask** function, disable the **Enable Privacy Mask** check box.

4.7 Event Setup Execution

Clicking the **Event** button will display the tabbed panes (see figure below) for defining event recording of the Camera. The ICA-W8100/ICA-W8100-CLD is equipped with a card slot for Micro-SD/SDHC memory card.

This storage card is utilized to store recording of local video and still JPEG images taken in response to set events. The recording operation of events is triggered according to the defined schedules

4.7.1 Motion Tab

From the **Motion** tabbed pane, you can define specific target areas within the scope of surveillance to focus the motion detection function.

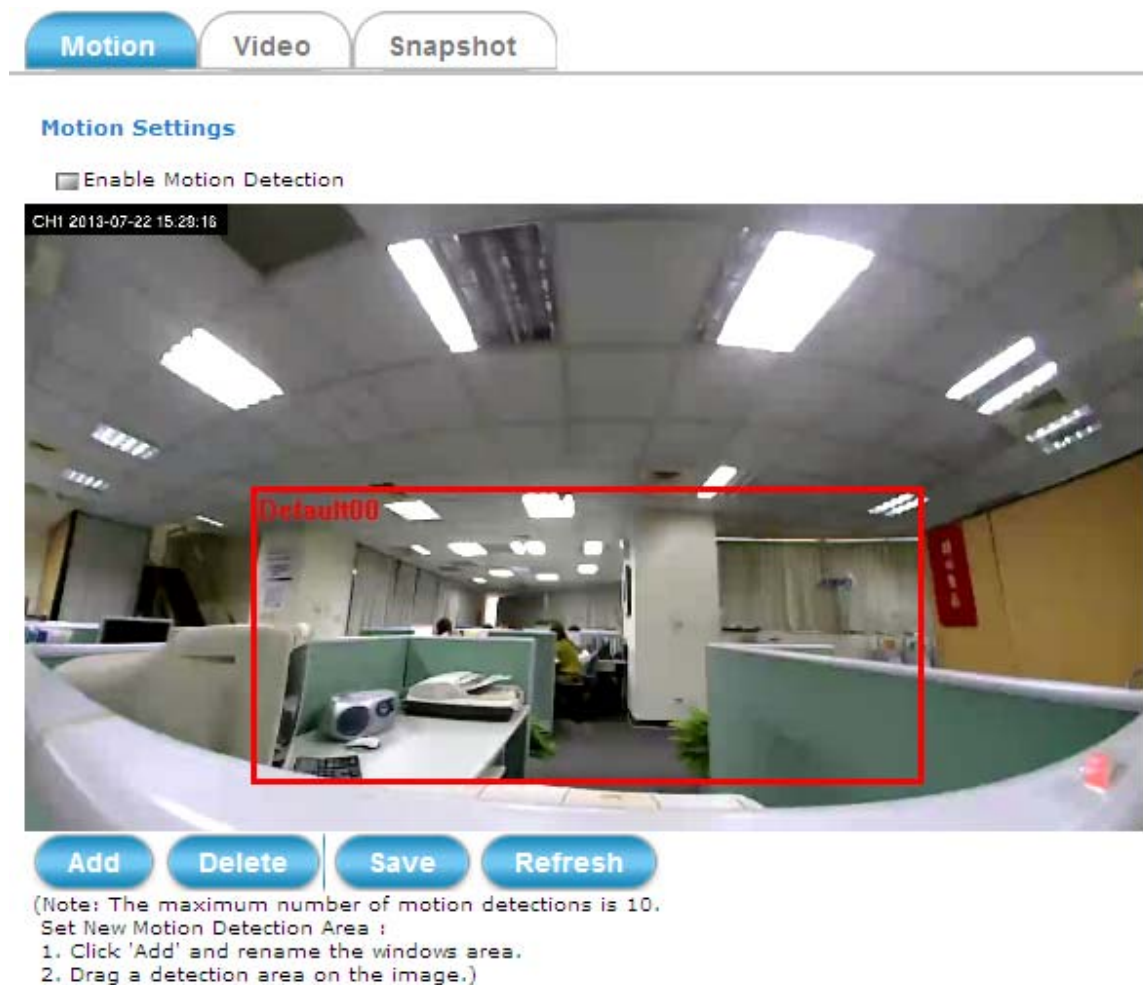

Motion Settings

Enable Motion Detection

CH1 2013-07-22 15:29:16

Default00

Add Delete Save Refresh

(Note: The maximum number of motion detections is 10.
Set New Motion Detection Area :
1. Click 'Add' and rename the windows area.
2. Drag a detection area on the image.)

■ Defining a single motion detection area:

Step 1. Enable the **Enable Motion Detection** check box.

Step 2. Click **Add** button and a default frame will pop-up on the screen.

Step 3. Click and hold inside the frame to drag it to the location where you want to focus detection. Resize the frame by dragging its corners or borders.

Step 4. Click the **Save** button to apply.

■ Defining multiple motion detection areas:

Step 1. After satisfactory positioning of the first detection area as described above, click the **Add** button again. A second default frame will pop-up on the screen. Drag & resize the frame at the desired location.

Step 2. Repeat the above step to add more detection area frames.

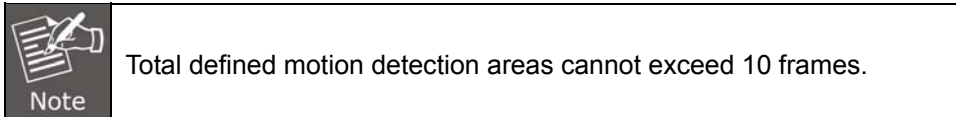

Step 3. To assign unique names to each framed location for easy identification, click on the frame and a **Window Name** text box with the default name of the selected frame, will appear at the bottom of the pane (see figure below). Enter a new name and click the **Save** button. Wait for a while for the change to take effect.

Window Name:

Object size: 85 (0~100, Low~High)

Sensitivity: 85 (0~100, Low~High)

Step 4. To delete a frame that is no longer needed but was previously saved, click on the unwanted frame and click **Delete** button. The frame will disappear after a while.

Step 5. To delete multiple frames that are not yet saved, directly click the **Refresh** button instead of deleting them individually. The **Refresh** button will automatically clears all unsaved frames.

4.7.2 Video Tab

The Video tabbed pane sets the video recording trigger method to use when motion is detected by the Camera. The four methods available for selection are Period, Schedule, Motion, and PIR (passive infrared), each of which can be set up with user scheduled recording time and duration, as well as defining the video record file target destination.

 Note	Only the ICA-W8100-CLD enables Motion/PIR to trigger video recording and bind into CloudLync Cloud Service with Google account. The recorded video files in the SD Memory Card will be uploaded and backed-up to your Google Drive synchronously.
---	---

■ Trigger by Period

Motion Video Snapshot

Event Alarm Settings by Video

Video Clip

Trigger by: Period ▼

Video Clip Type:

Maximum duration: 5 ▼ Seconds

Time Lapse: 10 ▼ Seconds

Period	This method will trigger the camera video surveillance/recording operation for a defined duration (in seconds) whenever motion is detected. The video record may be sent to host by e-mail or stored in the SD card as selected.
---------------	--

■ Trigger by Schedule

Motion Video Snapshot

Event Alarm Settings by Video

Video Clip

Trigger by: Schedule ▼

Day: Sun MON Tue WED Thu FRI Sat

Time: Start 00 ▼ : 00 ▼ (hh:mm) End 24 ▼ : 00 ▼ (hh:mm)

Video Clip Type:

Maximum duration: 60 ▼ Seconds

Schedule	This method activates the camera video surveillance/recording operation continuously when the defined days of the week and set time of the set days are met. Motion is ignored with this method. Each recording time-span is in accordance with the set duration (in seconds) and the video record is stored in the SD card.
-----------------	--

■ Trigger by Motion

Event Alarm Settings by Video

Video Clip

Trigger by: [Link to Motion Settings](#)

Only during

Day:

Sun MON Tue WED Thu FRI Sat

Time:

Start : (hh:mm) End : (hh:mm)

Video Clip Type:

Maximum duration: Seconds

Motion	This method will trigger the camera video surveillance/recording operation according to the set duration (in seconds) whenever motion is detected within the defined days of the week and at the time of the set days. The video record may be sent to host by e-mail or stored in the SD card as selected.
---------------	---

■ Trigger by PIR

Motion
Video
Snapshot

Event Alarm Settings by Video

Video Clip

Trigger by: PIR

Only during

Day:

Sun MON Tue WED Thu FRI Sat

Time:

Start 00 : 00 (hh:mm) End 24 : 00 (hh:mm)

Video Clip Type:

Maximum duration: 5 Seconds

PIR	On the defined days of the week and at certain time of the set days, the camera will trigger its PIR operation when it senses abrupt changes in temperature or detects motion. Recording duration can be set in seconds and the video record may be sent to host by e-mail or stored in the SD card.
------------	--

4.7.3 Snapshot Tab

The Snapshot tabbed pane sets the camera to take snapshot images when motion is detected. The four methods available for selection are Always, Schedule, Motion, and PIR (passive infrared), each of which can be set up with user scheduled recording time and duration, as well as defining the video record file target destination.

■ Trigger by Always

Motion
Video
Snapshot

Event Alarm Settings by Snapshot

Snapshot

Trigger by: Always

Snapshot Type:

6 snapshot with 1 second interval (3 frames before and 3 frames after motion frame)

Always Under this method, the camera automatically continuous to capture 6 snapshots of the area under surveillance at every 1 or 2 seconds interval. 3 previous snapshot frames are collected from the Camera buffer and 3 snapshot frames are captured live. The stream of accumulated snapshots may be sent to host by e-mail, FTP, or stored in the SD card as preferred.

■ Trigger by Schedule

Motion Video **Snapshot**

Event Alarm Settings by Snapshot

Snapshot

Trigger by:

Day:

Sun MON Tue WED Thu FRI Sat

Time:

Start : (hh:mm) End : (hh:mm)

Snapshot Type:

6 snapshot with second interval (3 frames before and 3 frames after motion frame)

Schedule This method activates the camera snapshot operation continuously when the defined days of the week and set time of the set days are met. The camera will continuously capture 6 snapshots of the area under surveillance at every 1 or 2 seconds interval. 3 previous snapshot frames are collected from the camera buffer and 3 snapshot frames are captured live. The stream of accumulated snapshots may be sent to host by e-mail, FTP, or stored in the SD card as preferred.

■ Trigger by Motion

Motion
Video
Snapshot

Event Alarm Settings by Snapshot

Snapshot

Trigger by: Motion [Link to Motion Settings](#)

Only during

Day: Sun MON Tue WED Thu FRI Sat

Time: Start 00 : 00 (hh:mm) End 24 : 00 (hh:mm)

Snapshot Type:

Interval: 3 (minimum is 3 seconds)

Single snapshot

6 snapshot with 1 second interval (3 frames before and 3 frames after motion frame)

Motion	This method will trigger the camera snapshot operation according to the set time interval (in seconds) whenever motion is detected within the defined days of the week and at the time of the set days. Single or 6 snapshots may be captured as defined. The stream of accumulated snapshots may be sent to host by e-mail, FTP, or stored in the SD card as preferred.
---------------	--

■ Trigger by PIR

Motion
Video
Snapshot

Event Alarm Settings by Snapshot

Snapshot

Trigger by: PIR

Only during

Day: Sun MON Tue WED Thu FRI Sat

Time: Start 00 : 00 (hh:mm) End 24 : 00 (hh:mm)

Snapshot Type:

Interval: 3 (minimum is 3 seconds)

Single snapshot

6 snapshot with 1 second interval (3 frames before and 3 frames after motion frame)

PIR	On the defined days of the week and at certain time of the set days, the camera will trigger its PIR operation according to the set time interval (in seconds) when it senses abrupt changes in temperature or detects motion. Single or 6 snapshots may be captured at a time as defined.
------------	--

■ Trigger to E-mail, FTP, SD card

The stream of accumulated snapshots may be sent to host through e-mail, FTP, or stored in the SD card per selection or through all 3 available methods. When selected, the setup dialog for these methods will display as illustrated in the following figure.

Target to:

E-mail

Recipient E-mail Address: (ex: rcpt@mail.com)

SMTP E-mail Server: (ex: mail.examples.com or 192.168.1.1)

Port: (0..65535)

User Name:

Password:

Sender E-mail Address: (ex: from@mail.com)

Use SSL-TLS: ▾

Test E-mail

FTP

FTP Server: (ex: ftp.domain.com or 192.168.1.1)

FTP Server Port: (0..65535)

User Name:

Password:

Path: (ex: ftp/upload)

Filename Prefix: (ex: event)

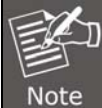

Note

1. As for the settings of SMTP service, kindly please contact your e-mail service provider. After you confirm all parameters are correct and working properly, you may enter them into the text area manually.
2. As for the settings of FTP Service, kindly please contact your FTP service provider. While all parameters filled in Windows FTP Transferring Utility are correct and working properly under your Laptop or other PC, you may enter them into the text area manually.

4.8 Local Storage Setup Execution

Clicking the **Local Storage** button will display the following tabbed panes to provide information on existing local storage, such as disk size info, type, and status. If recording is in progress when clicking the **Local Storage** button, a warning message will occur.

4.8.1 Local Storage Tab

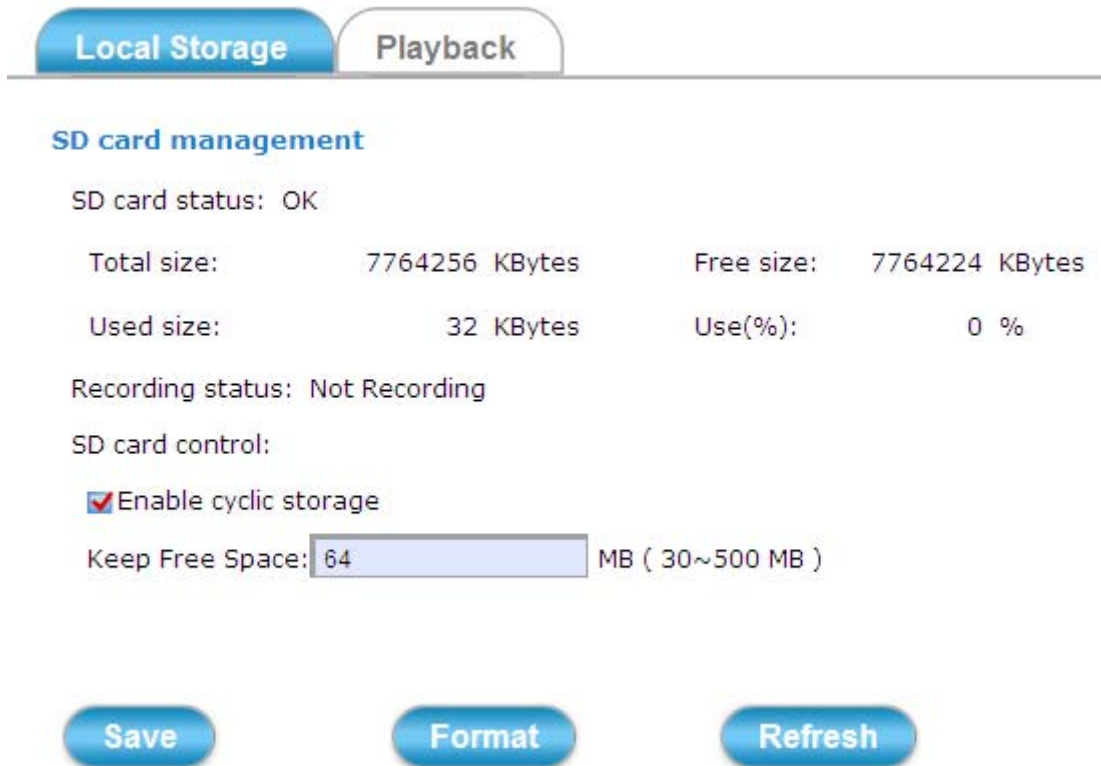

Local Storage Playback

SD card management

SD card status: OK

Total size:	7764256 KBytes	Free size:	7764224 KBytes
Used size:	32 KBytes	Use(%):	0 %

Recording status: Not Recording

SD card control:

Enable cyclic storage

Keep Free Space: MB (30~500 MB)

Save Format Refresh

Save	Click this button to save changes to the SD card control setting.
Format	Click this button to format the SD memory card (take note of the message in red).
Refresh	Click this button to refresh the webpage.



4.8.2 Playback Tab

The **Playback** tabbed pane allows user to playback video and snapshot files stored in the SD memory card. These files were saved using the Event setup for video and snapshots with the **SD card** check box enabled.

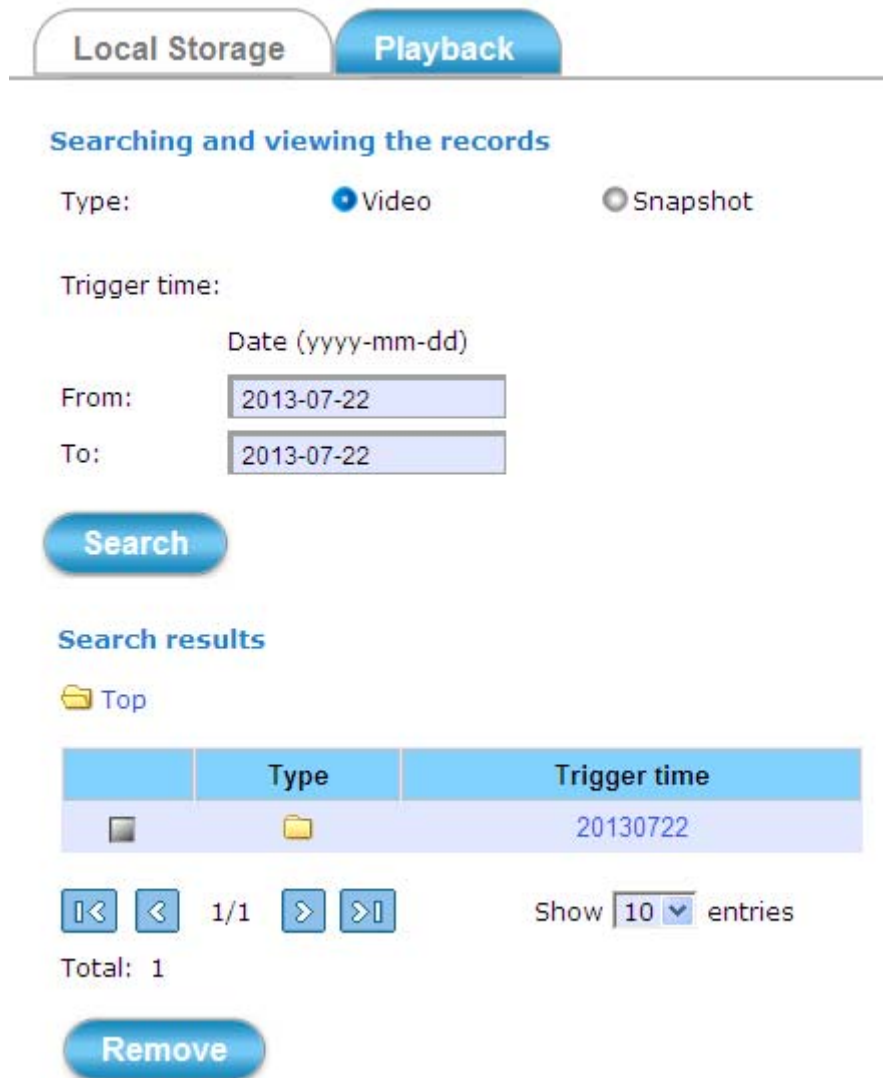
Playback of the stored videos or snapshots is performed from files recorded on particular date range as explained in the following figure.



The screenshot shows the 'Playback' tab selected. Under 'Searching and viewing the records', the 'Type' is set to 'Video' and 'Snapshot' is unselected. The 'Trigger time' section has 'From' and 'To' date pickers both set to '2013-07-22'. A 'Search' button is present. Below, the 'Search results' section shows a folder icon labeled 'Top'. A table displays one result:

	Type	Trigger time
		20130722

Navigation controls include left and right arrows, a '1/1' indicator, and a 'Show 10 entries' dropdown. A 'Total: 1' label and a 'Remove' button are also visible.

4.9 CloudLync Setup Execution (For ICA-W8100-CLD)

Clicking the **CloudLync** button will enter the <http://www.cloudlync.net/index.php>.

Appendix A: PING IP Address

The PING (stands for Packet Internet Groper) command is used to detect whether a specific IP address is accessible by sending a packet to the specific address and waiting for a reply. It's also a very useful tool to confirm the installation of Internet camera, or if the IP address conflicts with any other device over the network.

If you want to make sure the IP address of Internet camera is right, utilize the PING command as follows:

Start a DOS window.

Type ping x.x.x.x, where x.x.x.x is the IP address of the Internet camera.

The replies, as illustrated below, will provide an explanation to the problem.



```
Microsoft Windows XP [Version 5.1.2600]
(C) Copyright 1985-2001 Microsoft Corp.

D:\Documents and Settings\Administrator>PING 192.168.0.20

Pinging 192.168.0.20 with 32 bytes of data:

Reply from 192.168.0.20: bytes=32 time<1ms TTL=64
Reply from 192.168.0.20: bytes=32 time<1ms TTL=64
Reply from 192.168.0.20: bytes=32 time<1ms TTL=64
Reply from 192.168.0.20: bytes=32 time<1ms TTL=64

Ping statistics for 192.168.0.20:
    Packets: Sent = 4, Received = 4, Lost = 0 (0% loss),
    Approximate round trip times in milli-seconds:
        Minimum = 0ms, Maximum = 1ms, Average = 0ms

D:\Documents and Settings\Administrator>_
```

If you want to detect any other device that conflicts with the IP address of Internet camera, you also can utilize the PING command but you must disconnect the Internet camera from the network first.

Appendix B: DDNS Application

Configure PLANET DDNS with the following steps:

Step 1. Enable DDNS option through accessing web page of NAS

Step 2. Select on DDNS server provided, and register an account if you have not used yet.

Let's take dyndns.org as an example. Register an account in <http://planetddns.com>

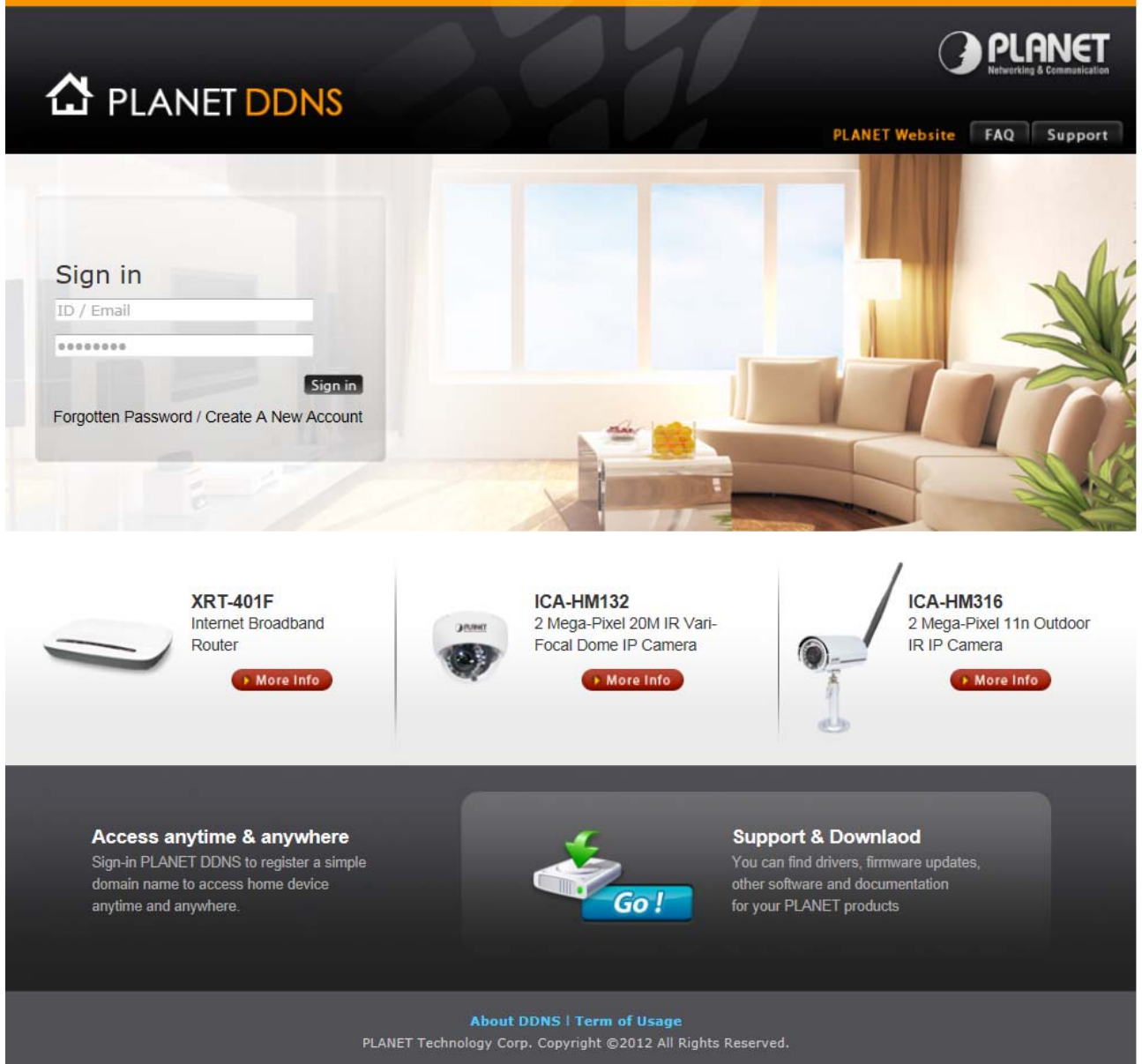

PLANET DDNS

PLANET Website FAQ Support

Sign in

ID / Email

.....

Sign in

Forgotten Password / Create A New Account

XRT-401F
Internet Broadband Router
[More Info](#)

ICA-HM132
2 Mega-Pixel 20M IR Vari-Focal Dome IP Camera
[More Info](#)

ICA-HM316
2 Mega-Pixel 11n Outdoor IR IP Camera
[More Info](#)

Access anytime & anywhere
Sign-in PLANET DDNS to register a simple domain name to access home device anytime and anywhere.

Support & Download
You can find drivers, firmware updates, other software and documentation for your PLANET products

[Go!](#)

[About DDNS](#) | [Term of Usage](#)
PLANET Technology Corp. Copyright ©2012 All Rights Reserved.

Appendix C: Configuring Port Forwarding Manually

The device can be used with a router. If the device wants to be accessed from the WAN, its IP address needs to be set up as fixed IP address, also the port forwarding or Virtual Server function of router needs to be set up. This device supports UPnP traversal function. Therefore, user could use this feature to configure port forwarding of NAT router first. However, if user needs to configure port forwarding manually, please follow the steps below:

Manually installing the device with a router on your network is an easy 3–step procedure as shown below:

1. Assign a local/fixed IP address to your device
2. Access the router with your Web browser
3. Open/Configure Virtual Server Ports of your router

1. Assign a local/fixed IP address to your device

The device must be assigned a local and fixed IP Address that allows it to be recognized by the router. Manually set up the device with a fixed IP address, for example, *192.168.0.100*.

2. Access the Router with Your Web browser

The following steps generally apply to any router that you have on your network. PLANET WNRT-620 is used as an example to clarify the configuration process. Configure the initial settings of the router by following the steps outlined in the router's **Quick Installation Guide**.

If you have cable or DSL service, you will most likely have a dynamically assigned WAN IP Address. 'Dynamic' means that your router's WAN IP address can be changed from time to time depending on your ISP. A dynamic WAN IP Address identifies your router on the public network and allows it to access the Internet. To find out what your router's WAN IP Address is, go to the **Status** screen on your router and locate the WAN information for your router. As shown on the following page the WAN IP Address will be listed. This will be the address that you will need to type in your web browser to view your camera over the Internet. Be sure to uncheck the **Reset IP address at next boot** button at the top of the screen after modifying the IP address. Failure to do so will reset the IP address when you restart your computer.

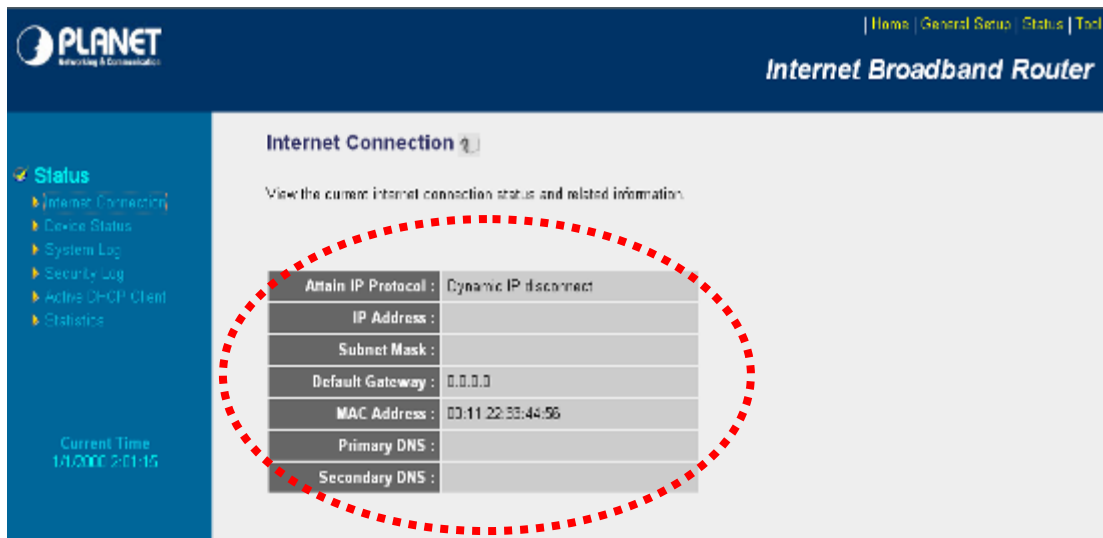

Your WAN IP Address will be listed here.

3. Open/set Virtual Server Ports to enable remote image viewing

The firewall security features built into the router and most routers prevent users from accessing the video from the device over the Internet. The router connects to the Internet over a series of numbered ports. The ports normally used by the device are blocked from access over the Internet. Therefore, these ports need to be made accessible over the Internet. This is accomplished using the **Virtual Server** function on the router. The Virtual Server ports used by the camera must be opened through the router for remote access to your camera.

Follow these steps to configure your router's Virtual Server settings

- Click **Enabled**.
- Enter a unique name for each entry.
- Select **Both** under **Protocol Type (TCP and UDP)**
- Enter your camera's local IP Address (e.g., **192.168.0.100**, for example) in the **Private IP** field.
- If you are using the default camera port settings, enter **80** into the **Public and Private Port** section, click **Add**.

A check mark appearing before the entry name will indicate that the ports are enabled.



Some ISPs block access to port 80. Be sure to check with your ISP so that you can open the appropriate ports accordingly. If your ISP does not pass traffic on port 80, you will need to change the port the camera uses from 80 to something else, such as 8080. Not all routers are the same, so refer to your user manual for specific instructions on how to open ports.

| Home | General Setup | Status | Tool |

Internet Broadband Router

- System
- WAN
- LAN
- Wireless
- QoS
- NAT
 - ▶ Port Forwarding
 - ▶ **Virtual Server**
 - ▶ Special applications
 - ▶ UPnP Setting
 - ▶ ALG Settings
- Firewall

Virtual Server ?

You can configure the Broadband router as a Virtual Server so that remote users accessing services such as the Web or FTP at your local site via Public IP Addresses can be automatically redirected to local servers configured with Private IP Addresses. In other words, depending on the requested service (TCP/UDP) port number, the Broadband router redirects the external service request to the appropriate internal server (located at one of your LAN's Private IP Address).

Enable Virtual Server

Private IP	Private Port	Type	Public Port	Comment
<input style="width: 90%;" type="text"/>	<input style="width: 90%;" type="text"/>	Both ▼	<input style="width: 90%;" type="text"/>	<input style="width: 90%;" type="text"/>

Current Virtual Server Table

NO.	Private IP	Private Port	Type	Public Port	Comment	Select
<input type="button" value="Delete Selected"/> <input type="button" value="Delete All"/> <input type="button" value="Reset"/>						

Enter valid ports in the **Virtual Server** section of your router. Please make sure to check the box on this line to enable settings. Then the device can be accessed from WAN by the router's WAN IP Address.

By now, you have finished your entire PC configuration for this device.

Appendix D: Troubleshooting & Frequently Asked Questions

Features	
The video and audio codec is adopted in the device.	The device utilizes H.264 and M-JPEG triple compression to provide high quality images. Where H.264 is standard for video compression, M-JPEG is standard for image compression. The audio codec is defined as u-Law for RTSP streaming.
The maximum number of users accessing device simultaneously.	The maximum number of users is limited to 10. However, it also depends on the total bandwidth accessed to this device from clients. The maximum data throughput of the device is around 20~25Mbps for UDP mode and 10Mbps for HTTP mode. Therefore, the actual number of connected clients is varying by streaming mode, settings of resolution, codec type, frame rate and bandwidth. Obviously, the performance of the each connected client will slow down when many users are logged on.
The device can be used outdoors or not.	The device is not weatherproof. It needs to be equipped with a weatherproof case for outdoor use. However, when equipped with a weatherproof case, it might disable the audio function of the device.
Install this device	
Status LED does not light up.	Check and confirm that the DC power adaptor, included in the package, is used. Secure the power connector and re-power it on.
The network cabling is required for the device.	The device uses Category 5 UTP cable allowing 10 and/or 100 Base-T networking.
The device will be installed and work if a firewall exists on the network.	If a firewall exists on the network, port 80 is open for ordinary data communication. The HTTP port and RTSP port need to be opened on the firewall or NAT router.
The username and password for the first time or after factory default reset	Username = admin and leave password = admin . Note that it's all case sensitivity.
Forgot the username and password	Follow the steps below. 1. Restore the factory default setting by pressing and holding down for more than 30 seconds on the device. 2. Reconfigure the device.
Forgot the IP address of the device.	Check IP address of device by using the IPInstaller program or by UPnP discovery or set the device to default by Reset button.
PLANET IPInstaller program	<ul style="list-style-type: none"> ● Re-power the device if cannot find the unit within 1 minutes.

cannot find the device.	<ul style="list-style-type: none"> ● Do not connect device over a router. IPInstaller program cannot detect device over a router. ● If IP address is not assigned to the PC which is running IPInstaller program, then the program cannot find device. Make sure that IP address is assigned to the PC properly. ● Antivirus software on the PC might interfere with the setup program. Disable the firewall of the antivirus software during the setting up of this device. ● Check the firewall setting of your PC or Notebook.
Internet Explorer does not seem to work well with the device	Make sure that your Internet Explorer is version 8.0 or later. If you are experiencing problems, try upgrading to the latest version of Microsoft's Internet Explorer from the Microsoft webpage.
PLANET IPInstaller program fails to save the network parameters.	Network may have trouble. Confirm the parameters and connections of the device.
UPnP NAT Traversal	
Cannot work with NAT router	Maybe NAT router does not support UPnP function. Please check user's manual of router and turn on UPnP function.
Some IP cameras are working but others failed	Maybe too many Internet cameras have been installed on the LAN, and then NAT router is out of resource to support more cameras. You can turn off and on NAT router to clear out of date information inside router.
Access this device	
Cannot access the login page and other web pages of the Network camera from Internet Explorer	<ul style="list-style-type: none"> ● Maybe the IP Address of the Internet camera is already being used by another device or computer. To confirm this possible problem, disconnect the Network camera from the network first, and then run the PING utility to check it out. ● Maybe due to the network cable. Try correcting your network cable and configuration. Test the network interface by connecting a local computer to the Network camera via a crossover cable. ● Make sure the Internet connection and setting is ok. ● Make sure that entering the IP address of Internet Explorer is correct. If the Internet camera has a dynamic address, it may have changed since you last checked it. ● Network congestion may prevent the web page appearing quickly. Wait for a while. <p>The IP address and Subnet Mask of the PC and Network camera must be in the same class of the private IP address on the LAN.</p> <ul style="list-style-type: none"> ● Make sure the http port used by the Network camera, default=80, is forward to the Network camera's private IP address. ● The port number assigned in your Internet camera might not be

	<p>available via Internet. Check your ISP for available port.</p> <ul style="list-style-type: none"> ● The proxy server may prevent you from connecting directly to the Network camera. Do not use the proxy server while setting up. ● Confirm that Default Gateway address is correct. ● The router needs Port Forwarding feature. Refer to your router's manual for details. ● Packet Filtering of the router may prohibit access from an external network. Refer to your router's manual for details. ● Access the Network camera from the Internet with the global IP address of the router and port number of Network camera. ● Some routers reject the global IP address to access the Network camera on the same LAN. Access with the private IP address and correct port number of Network camera. ● When you use DDNS, you need to set Default Gateway and DNS server address. ● If it's not working after the above procedure, reset Network camera to default setting and install it again.
<p>Image or video does not appear on the main page.</p>	<ul style="list-style-type: none"> ● The first time the PC connects to Internet camera, a pop-up Security Warning window will appear to download ActiveX Controls. When using Windows XP, or Vista, log on with an appropriate account that is authorized to install applications. ● Network congestion may prevent the Image screen from appearing quickly. You may choose lower resolution to reduce the required bandwidth.
<p>How to check whether the device's ActiveX is installed on your computer</p>	<p>Go to C:\Windows\Downloaded Program Files and check to see if there is an entry for the file "PControl". The status column should show "Installed". If the file is not listed, make sure your Security Settings in Internet Explorer are configured properly and then try reloading the device's home page. Most likely, the ActiveX control did not download and install correctly. Check your Internet Explorer security settings and then close and restart Internet Explorer. Try to browse and log in again.</p>
<p>Internet Explorer displays the following message: "Your current security settings prohibit downloading ActiveX controls".</p>	<p>Set up the IE security settings or configure the individual settings to allow downloading and scripting of ActiveX controls.</p>
<p>The device work locally but not externally.</p>	<ul style="list-style-type: none"> ● Might be caused from the firewall protection. Check the Internet firewall with your system or network administrator. The firewall may need to have some settings changed in order for the device to be accessible outside your LAN. ● Make sure that the device isn't conflicting with any other web server running on your LAN. ● Check the configuration of the router settings to allow the device

	<p>to be accessed outside your local LAN.</p> <ul style="list-style-type: none"> ● Check the bandwidth of Internet connection. If the Internet bandwidth is lower than target bit rate, the video streaming will not work correctly.
Image Transfer on e-mail or FTP does not work.	<ul style="list-style-type: none"> ● Default Gateway and DNS server address should be set up correctly. ● If FTP does not work properly, ask your ISP or network administrator about the transferring mode of FTP server.
Video quality of the device	
The focus on the camera is bad.	The lens is dirty or dust is attached. Fingerprints, dust, stain, etc. on the lens can degrade the image quality.
The color of the image is poor or strange.	<ul style="list-style-type: none"> ● Adjust White Balance. ● To ensure the images you are viewing are the best they can be, set the Display property setting (color quality) to 16bit at least and 24 bit or higher if possible within your computer. ● The configuration on the device image display is incorrect. You need to adjust the image related parameters such as brightness, contrast, hue and sharpness properly.
Miscellaneous	
Cannot play the recorded .h264 file	Please install VLC player to play the H264 file recorded by the device.

Appendix E: EC Declaration of Conformity

English	Hereby, PLANET Technology Corporation declares that this Wireless Cube Fish-Eye IP Camera is in compliance with the essential requirements and other relevant provisions of Directive 1999/5/EC.	Lietuviškai	Šiuo PLANET Technology Corporation , skelbia, kad Wireless Cube Fish-Eye IP Camera tenkina visus svarbiausius 1999/5/EC direktyvos reikalavimus ir kitas svarbias nuostatas.
Česky	Společnost PLANET Technology Corporation , tímto prohlašuje, že tato Wireless Cube Fish-Eye IP Camera splňuje základní požadavky a další příslušná ustanovení směrnice 1999/5/EC.	Magyar	A gyártó PLANET Technology Corporation , kijelenti, hogy ez a Wireless Cube Fish-Eye IP Camera megfelel az 1999/5/EK irányelv alapkövetelményeinek és a kapcsolódó rendelkezéseknek.
Dansk	PLANET Technology Corporation , erklærer herved, at følgende udstyr Wireless Cube Fish-Eye IP Camera overholder de væsentlige krav og øvrige relevante krav i direktiv 1999/5/EF	Malti	Hawnhekk, PLANET Technology Corporation , jiddikjara li dan Wireless Cube Fish-Eye IP Camera jikkonforma mal-htigijiet essenzjali u ma provvedimenti oħrajn rilevanti li hemm fid-Dirrettiva 1999/5/EC
Deutsch	Hiermit erklärt PLANET Technology Corporation , dass sich dieses Gerät Wireless Cube Fish-Eye IP Camera in Übereinstimmung mit den grundlegenden Anforderungen und den anderen relevanten Vorschriften der Richtlinie 1999/5/EG befindet". (BMWi)	Nederlands	Hierbij verklaart, PLANET Technology Corporation , dat Wireless Cube Fish-Eye IP Camera in overeenstemming is met de essentiële eisen en de andere relevante bepalingen van richtlijn 1999/5/EG
Eesti keeles	Käesolevaga kinnitab PLANET Technology Corporation , et see Wireless Cube Fish-Eye IP Camera vastab Euroopa Nõukogu direktiivi 1999/5/EC põhinõuetele ja muudele olulistele tingimustele.	Polski	Niniejszym firma PLANET Technology Corporation , oświadcza, że Wireless Cube Fish-Eye IP Camera spełnia wszystkie istotne wymogi i klauzule zawarte w dokumencie „Directive 1999/5/EC”.
Ελληνικά	<i>ΜΕ ΤΗΝ ΠΑΡΟΥΣΑ, PLANET Technology Corporation, ΔΗΛΩΝΕΙ ΟΤΙ ΑΥΤΟ Wireless Cube Fish-Eye IP Camera ΣΥΜΜΟΡΦΩΝΕΤΑΙ ΠΡΟΣ ΤΙΣ ΟΥΣΙΩΔΕΙΣ ΑΠΑΙΤΗΣΕΙΣ ΚΑΙ ΤΙΣ ΛΟΙΠΕΣ ΣΧΕΤΙΚΕΣ ΔΙΑΤΑΞΕΙΣ ΤΗΣ ΟΔΗΓΙΑΣ 1999/5/ΕΚ</i>	Português	PLANET Technology Corporation , declara que este Wireless Cube Fish-Eye IP Camera está conforme com os requisitos essenciais e outras disposições da Directiva 1999/5/CE.
Español	Por medio de la presente, PLANET Technology Corporation , declara que Wireless Cube Fish-Eye IP Camera cumple con los requisitos esenciales y cualesquiera otras disposiciones aplicables o exigibles de la Directiva 1999/5/CE	Slovensky	Výrobca PLANET Technology Corporation , týmto deklaruje, že táto Wireless Cube Fish-Eye IP Camera je v súlade so základnými požiadavkami a ďalšími relevantnými predpismi smernice 1999/5/EC.
Français	Par la présente, PLANET Technology Corporation , déclare que les appareils du Wireless Cube Fish-Eye IP Camera sont conformes aux exigences essentielles et aux autres dispositions pertinentes de la directive 1999/5/CE	Slovensko	PLANET Technology Corporation , s tem potrjuje, da je ta Wireless Cube Fish-Eye IP Camera skladen/a z osnovnimi zahtevami in ustreznimi določili Direktive 1999/5/EC.
Italiano	Con la presente, PLANET Technology Corporation , dichiara che questo Wireless Cube Fish-Eye IP Camera è conforme ai requisiti essenziali ed alle altre disposizioni pertinenti stabilite dalla direttiva. 1999/5/CE.	Suomi	PLANET Technology Corporation , vakuuttaa täten että Wireless Cube Fish-Eye IP Camera tyyppinen laite on direktiivin 1999/5/EY oleellisten vaatimusten ja sitä koskevien direktiivin muiden ehtojen mukainen.
Latviski	Ar šo PLANET Technology Corporation , apliecina, ka šī Wireless Cube Fish-Eye IP Camera atbilst Direktīvas 1999/5/EK pamatprasībām un citiem atbilstošiem noteikumiem.	Svenska	Härmed intygar, PLANET Technology Corporation , att denna Wireless Cube Fish-Eye IP Camera står i överensstämmelse med de väsentliga egenskapskrav och övriga relevanta bestämmelser som framgår av direktiv 1999/5/EG.